

PARTS AND OPERATION MANUAL

MQ POWER MODEL DCA-500SSK WHISPERWATT™ GENERATOR (Standard)

© COPYRIGHT 2001, MULTIQUIP INC.

PARTS LIST NO C4872300004

Revision #1 (06/04/01)



MULTIQUIP INC.
18910 WILMINGTON AVE.
CARSON, CALIFORNIA 90746
310-537-3700
800-421-1244
FAX:310-537-3927
E-mail:mq@multiquip.com • www:multiquip.com

PARTS DEPARTMENT:

800-427-1244
FAX: 800-672-7877

SERVICE DEPARTMENT:

800-835-2551
FAX:310-638-8046



WARNING



CALIFORNIA — Proposition 65 Warning

Diesel engine exhaust and some of its constituents are known to the State of California to cause cancer, birth defects and other reproductive harm.

HERE'S HOW TO GET HELP

*PLEASE HAVE THE MODEL AND SERIAL NUMBER
ON-HAND WHEN CALLING*

PARTS DEPARTMENT

800/427-1244 or 310/537-3700

FAX: 800/672-7877 or 310/637-3284

SERVICE DEPARTMENT

800/835-2551 or 310/537-3700

FAX: 310/638-8046

WARRANTY DEPARTMENT

800/835-2551 or 310/537-3700

FAX: 310/638-8046

MAIN

800/421-1244 or 310/537-3700

FAX: 310 - 537-3927

TABLE OF CONTENTS

Here's How To Get Help	3	Generator Assembly	70-73
Table Of Contents	4	Control Box Assembly	74-79
Parts Ordering Procedures	5	Engine Radiator Assembly	80-83
Rules For Safe Operation	6-9	Engine Operating Panel Assembly	84-85
Towing	10	Output Terminal Assembly	86-89
Trailer Safety Guidelines	11-17	Battery Assembly	90-91
Trailer Wiring Diagram	18	Muffler Assembly	92-93
Air Brake Troubleshooting	19	Fuel Tank Assembly	94-95
Operation And Safety Decals	20-24	Enclosure #1 Assembly	96-97
Specifications	26	Enclosure #2 Assembly	98-101
General Information	27	Enclosure #3 Assembly	102-103
		Enclosure (Rubber Seals)	104-105
		Name Plate and Decals	106-109
		Terms and Conditions Of Sale — Parts	110

MQ Power DCA-500SSK AC Generator

Major Components	28
Dimensions (Top, Side, Front, and Rear)	30-31
Control Panel	32-33
Engine Operating Panel	34-35
Output Terminal Panel	36-41
Installation	42-43
Pre-Setup	44-47
Load Application	48
Generator Start-Up Procedure (Manual)	49-52
Generator Start-Up Procedure (Auto)	53
Generator Shut-Down Procedure	54
Maintenance	56-59
Generator Wiring Diagram	60
Engine Wiring Diagram	62-63
Troubleshooting (Engine)	64-65
Troubleshooting (Engine/Generator)	66
Troubleshooting MPEC	67
Explanation Of Codes In Remarks Column	68
Suggested Spare Parts	69

NOTE

Specification and part number are subject to change without notice.

- Dealer account number
- Dealer name and address
- Shipping address (if different than billing address)
- Return fax number
- Applicable model number
- Quantity, part number and description of each part
- Specify preferred method of shipment:
 - UPS Ground
 - UPS Second Day or Third Day*
 - UPS Next Day*
 - Federal Express Priority One (please provide us with your Federal Express account number)*
 - Airborne Express*
 - Truck or parcel post

**Normally shipped the same day the order is received, if prior to 2PM west coast time.*

Earn Extra Discounts when you order by FAX!

All parts orders which include complete part numbers and are received by fax qualify for the following extra discounts:

<u>Number of line items ordered</u>	<u>Additional Discount</u>
1-9 items	3%
10+ items**	5%

Get special freight allowances when you order 10 or more line items via FAX! **

- UPS Ground Service at no charge for freight
- PS Third Day Service at one-half of actual freight cost

No other allowances on freight shipped by any other carrier.

**Common nuts, bolts and washers (all items under \$1.00 list price) do not count towards the 10+ line items.

DISCOUNTS ARE SUBJECT TO CHANGE

Fax order discount and UPS special programs revised June 1, 1995

**Extra Fax Discount
for Domestic USA
Dealers Only**

**Up to 5%
extra savings!**

**UPS
Special**
For faxed orders only

**Now! Direct TOLL-FREE access
to our Parts Department!**

Toll-free nationwide:

800-421-1244

Toll-free FAX:

800/6-PARTS-7 • 800-672-7877

RULES FOR SAFE OPERATION

CAUTION:



Failure to follow instructions in this manual may lead to serious injury or even death! This equipment is to be operated by trained and qualified personnel only! This equipment is for industrial use only.

The following safety guidelines should always be used when operating the DCA-500SSK portable generator:

GENERAL SAFETY

- **DO NOT** operate or service this equipment before reading this entire manual.



- This equipment should not be operated by persons under 18 years of age.

- **NEVER** operate this equipment without proper protective clothing, shatterproof glasses, steel-toed boots and other protective devices required by the job.



- **NEVER** operate this equipment when not feeling well due to fatigue, illness or taking medicine.



- **NEVER** operate this equipment under the influence of drugs or alcohol.



- **NEVER** use accessories or attachments, which are not recommended by MQ Power for this equipment. Damage to the equipment and/or injury to user may result.

- Manufacturer does not assume responsibility for any accident due to equipment modifications.

- Whenever necessary, replace nameplate, operation and safety decals when they become difficult read.

- Always check the machine for loosened threads or bolts before starting.

- **NEVER** touch the hot exhaust manifold, muffler or cylinder. Allow these parts to cool before servicing engine or generator.



- **High Temperatures** – Allow the engine to cool before adding fuel or performing service and maintenance functions. Contact with *hot* components can cause serious burns.

- The engine of this generator requires an adequate free flow of cooling air. Never operate the generator in any enclosed or narrow area where free flow of the air is restricted. If the air flow is restricted it will cause serious damage to the generator or engine and may cause injury to people. The generator engine gives off **DEADLY** carbon monoxide gas.

CAUTION:



Always refuel in a well-ventilated area, away from sparks and open flames.



- Always use extreme caution when working with **flammable** liquids. When refueling, **stop the engine** and allow it to cool. **DO NOT smoke** around or near the machine. Fire or explosion could result from fuel vapors, or if fuel is spilled on a hot engine.

- **NEVER** operate the generator in an explosive atmosphere or near combustible materials. An explosion or fire could result causing severe *bodily harm or even death*.

- Topping-off to filler port is dangerous, as it tends to spill fuel.

RULES FOR SAFE OPERATION

CAUTION:

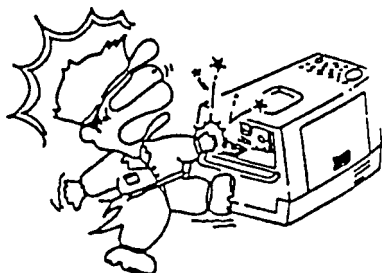

■ **NEVER** touch output terminals during operation. This is extremely dangerous. Always stop the machine when contact with the output terminals.

CAUTION:

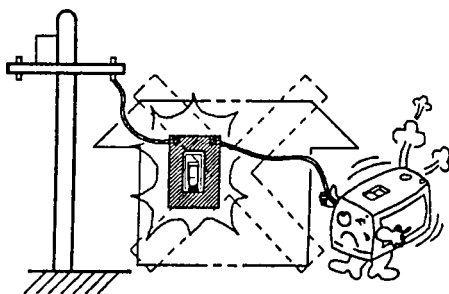

■ **Backfeed to a utility system can cause electrocution and/or property damage. Do not connect to any building's electrical system except through an approved device or after building main switch is opened.**

CAUTION:



Never use damaged or worn cables when connecting power tools or equipment to the generator. Make sure power connecting cables are securely connected to the generator's output terminals, insufficient tightening of the terminal connections may cause damage to the generator and electrical shock.

CAUTION:



DO NOT touch or open any of the below mentioned components while the generator is running. Always allow sufficient time for the engine and generator to cool before performing maintenance.

Radiator

1. **Radiator Cap** - Removing the radiator cap while the engine is hot will result in high pressurized, boiling water to gush out of the radiator, therefore causing severe scalding to any persons in the general area of the generator.
2. **Coolant Drain Plug** - Removing the coolant drain plug while the engine is hot will result in hot coolant to gush out of the coolant drain plug, therefore causing severe scalding to any persons in the general area of the generator.
3. **Engine Oil Drain Plug** - Removing the engine oil drain plug while the engine is hot will result in hot oil to gush out of the oil drain plug, therefore causing severe scalding to any persons in the general area of the generator.

Battery

CAUTION:



Never over fill the battery with water above the upper limit.

The battery contains acids that can cause injury to the eyes and skin. To avoid eye irritation, always wear safety glasses. Use well insulated gloves when picking up the battery. Use the following guidelines when handling the battery:

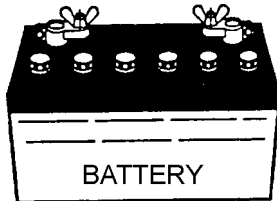

1. **DO NOT** drop the battery. There is the possibility of risk that the battery may explode.
2. **DO NOT** expose the battery to open flames, sparks, cigarettes etc. The battery contains combustible gases and liquids. If these gases and liquids come in contact with a flame or spark, an explosion could occur.
3. Always keep the battery charged. If the battery is not charged a buildup of combustible gas will occur.
4. Always keep battery charging and booster cables in good working condition. Repair or replace all worn cables.
5. Always recharge the battery in an open air environment, to avoid risk of a dangerous concentration of combustible gases.
6. In case the battery liquid (dilute sulfuric acid) comes in contact with **clothing or skin**, rinse skin or clothing immediately with plenty of water.
7. In case the battery liquid (dilute sulfuric acid) comes in contact with your **eyes**, rinse eyes immediately with plenty of water, then contact the nearest doctor or hospital, and seek medical attention.

- **NEVER** Run engine without air filter. Severe engine damage may occur.
- Always service air cleaner frequently to prevent carburetor malfunction.
- Always disconnect the battery before performing service on the generator.
- Always be sure the operator is familiar with proper safety precautions and operations techniques before using generator.
- Always store equipment properly when it is not being used. Equipment should be stored in a clean, dry location out of the reach of children.
- **DO NOT** leave the generator running in the manual mode unattended.
- **DO NOT** allow unauthorized people to operate this equipment.
- Always read, understand, and follow procedures in Operator's Manual before attempting to operate equipment.
- Always be sure the operator is familiar with proper safety precautions and operations techniques before using generator.
- Refer to the ***Komatsu Engine Owner's Manual*** for engine technical questions or information.

Loading and Unloading (Crane)

- Before lifting, make sure the generator's lifting hook is secure and that there is no apparent damage to the generator itself (loose screws, nuts and bolts). If any part is loose or damaged, please take corrective action before lifting.
- Always drain fuel prior to lifting.
- Always make sure crane or lifting device has been properly secured to the hook of guard frame on generator.
- **NEVER** lift the machine while the engine is running.
- Use adequate lifting cable (wire or rope) of sufficient strength.
- When lifting the generator, always use the balanced center-point suspension hook and lift straight upwards.
- **NEVER** allow any person or animal to stand underneath the machine while lifting.
- When loading the generator on a truck, be sure to use the front and back frame bars as a means to secure the generator during transport.

RULES FOR SAFE OPERATION

Transporting

- Always shutdown engine before transporting.
- Tighten fuel tank cap securely.
- Drain fuel when transporting generator over long distances or bad roads.
- Always tie-down the generator during transportation by securing the generator.
- If generator is mounted on a trailer, make sure trailer complies with all local and state safety transportation laws. See page 10 for basic towing procedures.

Emergencies

- Always know the location of the nearest **fire extinguisher** and **first aid kit**. Know the location of the nearest telephone. Also know the phone numbers of the nearest **ambulance**, **doctor** and **fire department**.

Maintenance Safety

- **NEVER** lubricate components or attempt service on a running machine.
- Always allow the machine a proper amount of time to cool before servicing.
- Keep the machinery in proper running condition.
- Fix damage to the machine immediately and always replace broken parts.
- Dispose of hazardous waste properly. Examples of potentially hazardous waste are used motor oil, fuel, and fuel filters.
- **DO NOT** use plastic containers to dispose of hazardous waste.
- **DO NOT** pour waste, oil or fuel directly onto the ground, down a drain or into any water source.

Towing Safety Precautions

CAUTION :



Check with your county or state safety towing regulations department before towing your generator.

To reduce the possibility of an accident while transporting the generator on public roads, always make sure the trailer (Figure 1) that supports the generator and the towing vehicle are in good operating condition and both units are mechanically sound.

The following list of suggestions should be used when towing your generator:

- Make sure the hitch and coupling of the towing vehicle are rated equal to, or greater than the trailer "gross vehicle weight rating" (GVWR).
- **ALWAYS** inspect the hitch and coupling for wear. **NEVER** tow a trailer with defective hitches, couplings, chains etc.
- Check the tire air pressure on both the towing vehicle and the trailer. Also check the tire tread wear on both vehicles.
- **ALWAYS** make sure the trailer is equipped with a "Safety Chain".

- **ALWAYS** attach trailer's safety chain to bumper of towing vehicle.
- **ALWAYS** make sure the vehicle and trailer directional, backup, brake, and trailer lights are connected and working properly.
- Remember the maximum speed unless otherwise posted for highway towing is **45 MPH**. Recommended off-road towing is not to exceed **10 MPH** or less depending on type of terrain.
- Place *chocked blocks* underneath wheel to prevent **rolling**, while parked.
- Place *support blocks* underneath the trailer's bumper to prevent **tipping**, while parked.
- Use the trailer's hand winch to adjust the height of the trailer, then insert locking pin to lock wheel stand in place, while parked.
- Avoid sudden stops and starts. This can cause skidding, or jackknifing. Smooth, gradual starts and stops will improve gas mileage.
- Avoid sharp turns to prevent rolling.
- Remove wheel stand when transporting.
- **DO NOT** transport generator with fuel in tank.

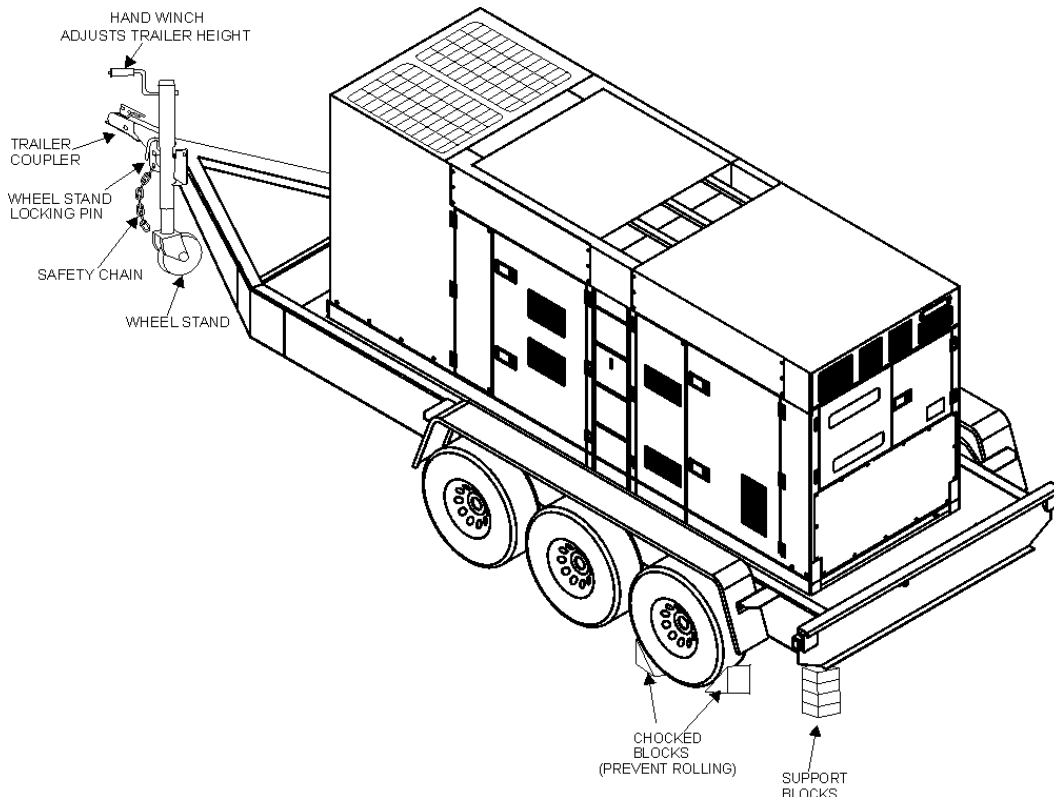

Figure 1. Generator and Trailer

CAUTION:



ALWAYS make sure the trailer is in good operating condition. Check the tires for proper inflation and wear. Also check the wheel lug nuts for proper tightness.

Explanation of Chart:

This section is intended to provide the user with trailer service and maintenance information. The service and maintenance guidelines referenced in this section apply a wide range of trailers. Remember periodic inspection of the trailer will ensure safe towing of the equipment and will prevent damage to the equipment and personal injury.

It is the purpose of this section to cover the major maintenance components of the trailer. The following trailer components will be discussed in this section:

- Brakes
- Tires
- Lug Nut Torquing
- Suspension
- Electrical
- Brake Troubleshooting Tables

Use the following definitions with reading Table 1.

1. **Fuel Cell** - Provides an adequate amount of fuel for the equipment in use. Fuel cells must be empty when transporting equipment.
2. **Braking System** - System employed in stopping the trailer. Typical braking systems are electric, surge, hydraulic, hydraulic-surge and air.
3. **GVWR**- Gross Vehicle Weight Rating (GVWR), is the maximum number of pounds the trailer can carry, including the fuel cell (empty).
4. **Frame Length** - This measurement is from the ball hitch to the rear bumper (reflector).
5. **Frame Width** - This measurement is from fender to fender.
6. **Jack Stand** - Trailer support device with maximum pound requirement from the tongue of the trailer.
7. **Coupler** - Type of hitch used on the trailer for towing.
8. **Tire Size** - Indicates the diameter of the tire in inches (10,12,14, etc.), and the width in millimeters (175,185,205, etc.). The tire diameter must match the diameter of the tire rim.
9. **Tire Ply** - The tire ply (layers) number is rated in letters; 2-ply,4-ply,6-ply, etc.
10. **Wheel Hub** - The wheel hub is connected to the trailer's axle.
11. **Tire Rim** - Tires mounted on a tire rim. The tire rim must match the size of the tire.
12. **Lug Nuts** - Used to secure the wheel to the wheel hub. Always use a torque wrench to tighten down the lug nuts. See Table 4 and Figure 5 or lug nut tightening and sequence.
13. **Axle** - Indicates the maximum weight the axle can support in pounds, and the diameter of the axle expressed in inches (see Table 3). Please note that some trailers have a double axle. This will be shown as 2-6000 lbs., meaning two axles with a total weight capacity of 6000 pounds.
14. **Suspension** - Protects the trailer chassis from shocks transmitted through the wheels. Types of suspension used are leaf, Q-flex, and air ride.
15. **Electrical** - Electrical connectors (looms) are provided with the trailer so the brake lights and turn signals can be connected to the towing vehicle.
16. **Application** - Indicates which units can be employed on a particular trailer.

DCA-500SSK — TRAILER-SPECIFICATIONS

Table 1. Specifications

MODEL	APPLICATION	FUEL CELL	BRAKE SYSTEM	GVWR	FRAME LENGTH	FRAME WIDTH	JACK STAND
TRLR-10W	SDW225, SGW250, TLW300	NO	NO	1900LBS	96"	50"	800LB. FULL TILT WHEEL
TRLR-10	DCA10, TLG12, DCA-15	NO	NO	1900LBS	96"	50"	800LB. FULL TILT WHEEL
TRLR-10XF	DCA10, TLG-12, DCA15, TLW-300	52 GAL	NO	1900LBS	96"	50"	800LB. FULL TILT WHEEL
TRLR-225W	WELDERS, DA7000SS	NO	NO	2200LBS	85"	42"	800LB. FULL TILT WHEEL
TRLR-BLW400	BLW-400	NO	ELECTRIC	2700LBS	W/MAST 154" W/O 124"	55" (78" TALL)	800LB. FULL TILT WHEEL
TRLR-50X	DCA-25	NO	NO	2700LBS	124"	55"	800LB. FULL TILT WHEEL
TRLR-50XF	DCA-25	41 GAL	NO	2700LBS	124"	55"	800LB. FULL TILT WHEEL
TRLR-70W	DCA-45, -60, 70	NO	SURGE	7000LBS	186"	77"	2000LB. FLAT PAD
TRLR-70X	DCA-45, -60, 70	OPT	SURGE	7000LBS	138"	66"	2000LB. FLAT PAD
TRLR-70XF	DCA-45, -60, 70	53 GAL	SURGE	7000LBS	138"	66"	2000LB. FLAT PAD
TRLR-100XF	DCA-100, 125	150 GAL	HYDRAULIC SURGE	7000LBS	190"	76"	2000LB. FLAT PAD
TRLR-85/125	DCA-85, 100, 125	145 GAL	HYDRAULIC	10000LBS	186"	77"	2000LB. FLAT PAD
TRLR-150XF	DCA-150, 180	200 GAL	HYDRAULIC SURGE	11160LBS	204"	84"	5000 LB. FLAT PAD
TRLR-220XF	DCA-220	250 GAL	HYDRAULIC SURGE	14000LBS	222"	83"	5000 LB. FLAT PAD
TRLR-300XF	DCA-300	250 GAL	HYDRAULIC SURGE	18000LBS	238"	83"	5000 LB. FLAT PAD
TRLR-400XF	DCA-400	350 GAL	ELECTRIC	18000LBS	238"	83"	5000 LB. FLAT PAD
TRLR-600XF	DCA-600, 800	550 GAL	AIR	30000LBS	384"	96"	5000 LB. FLAT PAD
TRLR-800SX	DCA-600, 800	550 GAL	AIR	30000LBS	384"	96"	5000 LB. FLAT PAD

DCA-500SSK —TRAILER-SPECIFICATIONS

Table 1. Specifications (Con't)

MODEL	COUPLER	TIRES	WHEELS	AXLE	HUBS	SUSPENSION	ELECTRICAL
TRLR-10W	2" BALL CLASS 2 ADJUSTABLE	175-13C	13"X4.50"	2200# 2X2	5 LUG	3 LEAF	4 WIRE LOOM W/ 4 POLE FLAT
TRLR-10	2" BALL CLASS 2 ADJUSTABLE	175-13C	13"X4.5"	2200#2X2	5 LUG	3 LEAF	4 POLE FLAT
TRLR-10XF	2" BALL CLASS 2 ADJUSTABLE	175-13C	13"X4.5"	2200#2X2	5 LUG	3 LEAF	4 POLE FLAT
TRLR-225W	2" BALL CLASS 2 ADJUSTABLE	175-13B	13X4.5"	2200#2X2	5 LUG	Q FLEX	4 POLE FLAT
TRLR-BLW 400	2" BALL CLASS 2 ADJUSTABLE	175-13C	13 X 4.5"	2200#2X2	5 LUG	3 LEAF	4 POLE FLAT
TRLR-50X	2" BALL CLASS	B78-13LRC	13"X4.50"	3500lbs. 2-3/8"	5 LUG	4 LEAF	4 POLE RUBBER FLAT
TRLR-50XF	2" BALL CLASS	B78-13LRC	13"X4.50"	3500lbs. 2-3/8"	5 LUG	4 LEAF	4 POLE RUBBER FLAT
TRLR-70W	2" BALL CLASS 3" ADJUSTABLE	205-14C BIAS (4)	14"X5"	3500lbs. 3"	5 LUG	5 LEAF	4 POLE RUBBER FLAT
TRLR-70X	2" BALL CLASS 3" ADJUSTABLE	205-14C BIAS (4)	14"X5"	3500lbs 3"	5 LUG	5 LEAF	4 POLE RUBBER FLAT
TRLR-70XF	2" BALL CLASS 3" ADJUSTABLE	205-14C BIAS (4)	14"X5"	3500lbs. 3"	5 LUG	5 LEAF	4 POLE RUBBER FLAT
TRLR-100XF	ADJUSTABLE 2-5/6 OPT 3" EYE	205-15C BIAS (4)	14"X5.5"	3500lbs 3"	5 LUG	5 LEAF	4 WIRE LOOM
TRLR-85/125	ADJUSTABLE 2-5/6 OPT 3" EYE	ST225/75R15D RADIAL (4)	14"x6"	(2)-6000lbs	6 LUG	7 LEAF	4 WIRE LOOM
TRLR-150XF	3" BALL EYE	750-16 E BIAS (4)	16"X7"	(2)-6000lbs	8 LUG	7 LEAF	4 WIRE LOOM
TRLR-220XF	3" EYE ADJUSTABLE	ST235/85R16E RADIAL(4)	16"X7"	(2)-7000lbs	8 LUG	Q FLEX	4 WIRE LOOM
TRLR-300XF	3" EYE ADJUSTABLE	ST235/85R16E RADIAL(6)	16"X7"	(2)-6000lbs	8 LUG	Q FLEX	4 WIRE LOOM
TRLR-400XF	3" EYE ADJUSTABLE	ST235/85R16E RADIAL(6)	16"X7"	(3)-7000lbs.	8 LUG	Q FLEX	4 WIRE LOOM
TRLR-600XF	5TH WHEEL	ST215/75R17.5H RADIAL (8)	16"X7"	(3)-10000lbs	8 LUG	7 LEAF	6 WIRE LOOM
TRLR-800AR	5TH WHEEL	ST215/75R17.5H RADIAL (8)	16"X7"	(3)-10000lbs	8 LUG	AIR-RIDE	6 WIRE LOOM

Brakes

If your trailer has a braking system, the brakes should be inspected the first 200 miles of operation. This will allow the brake shoes and drums to seat properly. After the first 200 mile interval, inspect the brakes every 3,000 miles. If driving over rough terrain, inspect the brakes more frequently.

Electric Brakes

Electrically actuated brakes (Figure 2) are similar to hydraulic brakes. The basic difference is that hydraulic brakes are actuated by an electromagnet.

Listed below are some of the advantages that electric brakes have over hydraulic brakes:

- Brake system can be manually adjusted to provide the corrected braking capability for varying road and load conditions
- Brake system can be modulated to provide more or less braking force, thus easing the brake load on the towing vehicle
- Brake system has very little lag time between the time the vehicle's brakes are actuated and the trailer's brakes are actuated
- Brake system can provide an independent emergency brake system

Remember in order to properly synchronize the tow vehicle's braking to the trailer's braking, can only be accomplished by road testing. Brake lockup, grabbiness or harshness is due to lack of synchronization between the tow vehicle and the trailer being towed or under-adjusted brakes.

Before any brake synchronizations adjustments can be made, the trailer brakes should be burnished-in by applying the brakes 20-30 times with approximately a 20 m.p.h. decrease in speed, e.g. 40 m.p.h. to 20 m.p.h. Allow ample time for brakes to cool between application. This allows the brake shoes to slightly be seated into the brake drum surface.

Figure 2 displays the major electric brake components that will require inspection and maintenance. Please inspect these components as required.

Electric Brake Adjustment

1. Place the trailer on jack stands. Make sure the jack stands are placed on secure level ground.
2. Check the wheel and drum for free rotation.
3. Remove the adjusting hole cover from the adjusting slot at the bottom brake backing plate.
4. With a screwdriver or standard adjusting tool, rotate the star wheel of the adjuster assembly to expand the brake shoes.
5. Adjust the brake shoes outward until the pressure of the lining against the wheel drum makes the wheel difficult to turn.
6. Rotate the star wheel in the opposite direction until the wheel rotates freely with slight lining drag.
7. Replace the adjusting hole cover and lower the trailer to the ground.
8. Repeat steps 1 through 6 on the remaining brakes.

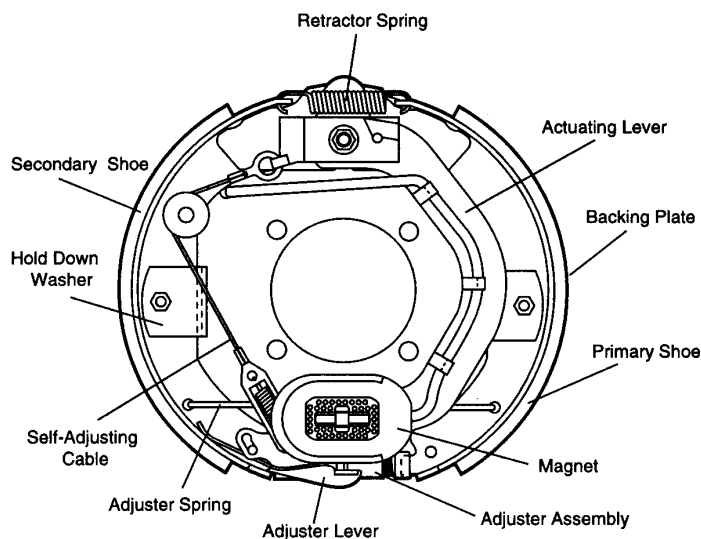

Figure 2. Electrical Brake Components

Hydraulic/Air/Surge Brakes

Hydraulic brakes (Figure 3) should not require any special attention with the exception of routine maintenance such as shoe and lining replacement. These brakes can be adjusted in the same manner as electric brakes. Brake lines should be periodically checked for cracks, kinks, or blockage. Figure 3 below displays the major hydraulic/air/surge brake

components that will require inspection and maintenance. Please inspect these components as required using steps 1 through 6 as referenced in the electric brake adjustments section.

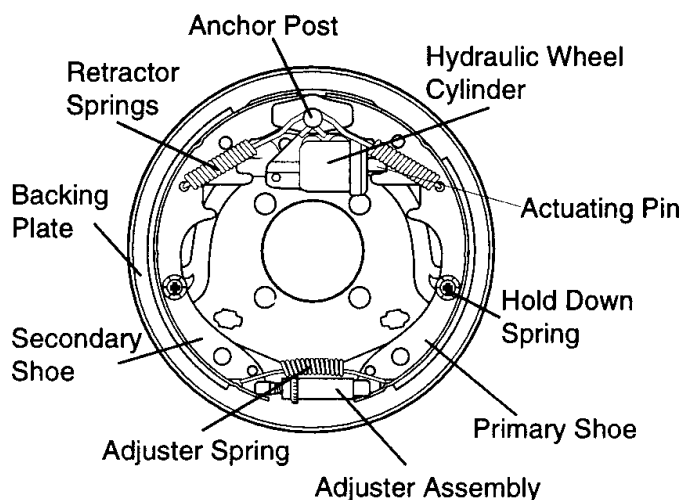

Figure 3. Hydraulic Brake Components

Tires/Wheels/Lug Nuts

Tires and wheels are a very important and critical components of the trailer. When specifying or replacing the trailer wheels it is important the wheels, tires, and axle are properly matched.

CAUTION:



DO NOT attempt to repair or modify a wheel. DO NOT install in inner tube to correct a leak through the rim. If the rim is cracked, the air pressure in the inner tube may cause pieces of the rim to explode (break off) with great force

and cause serious eye or bodily injury.

Tire Wear/Inflation

Tire inflation pressure is the most important factor in tire life. Pressure should be checked cold before operation DO NOT bleed air from tires when they are hot. Check inflation pressure weekly during use to insure the maximum tire life and tread wear.

Table 2 (Tire Wear Troubleshooting) will help pinpoint the causes and solutions of tire wear problems.



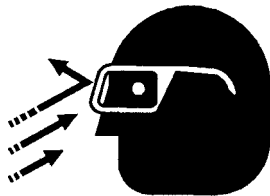



CAUTION:



NOTE

ALWAYS wear safety glasses when removing or installing force fitted parts. Failure to comply may result in serious injury.

TABLE 2. TIRE WEAR TROUBLESHOOTING

WEAR PATTERN	CAUSE	SOLUTION
 Center Wear	Over Inflation.	Adjust pressure to particular load per tire manufacturer.
 Edge Wear	Under Inflation.	Adjust pressure to particular load per tire manufacturer.
 Side Wear	Loss of chamber or overloading.	Make sure load does not exceed axle rating. Align wheels.
 Toe Wear	Incorrect toe-in.	Align wheels.
 Cupping	Out-of-balance.	Check bearing adjustment and balance tires.
 Flat Spots	Wheel lockup & tire skidding.	Avoid sudden stops when possible and adjust brakes.

Suspension

The leaf suspension springs and associated components (Figure 4) should be visually inspected every 6,000 miles for signs of excessive wear, elongation of bolt holes, and loosening of fasteners. Replace all damaged parts (suspension) immediately. Torqued suspension components as detailed in Table 3.

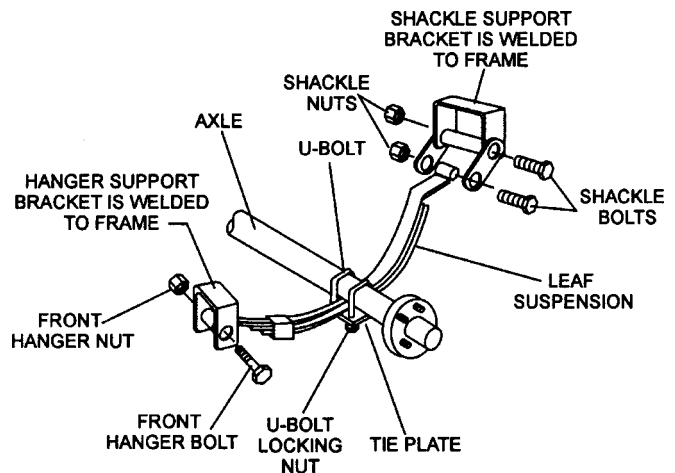

Figure 4. Major Suspension Components

Table 3. Suspension Torque Requirements

Item	Torque (Ft.-Lbs.)
3/8" U-BOLT	MIN-30 MAX-35
7/16" U-BOLT	MIN-45 MAX-60
1/2" U-BOLT	MIN-45 MAX-60
SHACKLE BOLT SPRING EYE BOLT	SNUG FIT ONLY. PARTS MUST ROTATE FREELY. LOCKING NUTS OR COTTER PINS ARE PROVIDED TO RETAIN NUT-BOLT ASSEMBLY.
SHOULDER TYPE SHACKLE BOLT	MIN-30 MAX-50

Lug Nut Torque Requirements

It is extremely important to apply and maintain proper wheel mounting torque on the trailer. Be sure to use only the fasteners matched to the cone angle of the wheel. Proper procedure for attachment of the wheels is as follows:

1. Start all wheel lug nuts by hand.
2. Torque all lug nuts in sequence. See Figure 5. **DO NOT** torque the wheel lug nuts all the way down. Tighten each lug nut in 3 separate passes as defined by Table 4.
3. After first road use, retorque all lug nuts in sequence. Check all wheel lug nuts periodically.

Table 4. Tire Torque Requirements

Wheel Size	First Pass FT-LBS	Second Pass FT-LBS	Third Pass FT-LBS
12"	20-25	35-40	50-65
13"	20-25	35-40	50-65
14"	20-25	50-60	90-120
15"	20-25	50-60	90-120
16"	20-25	50-60	90-120

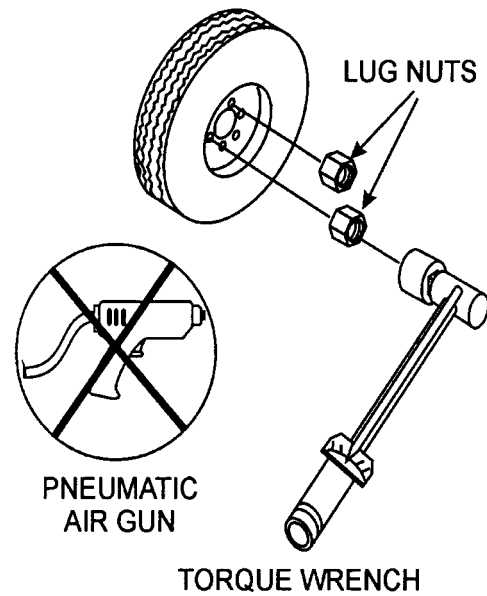
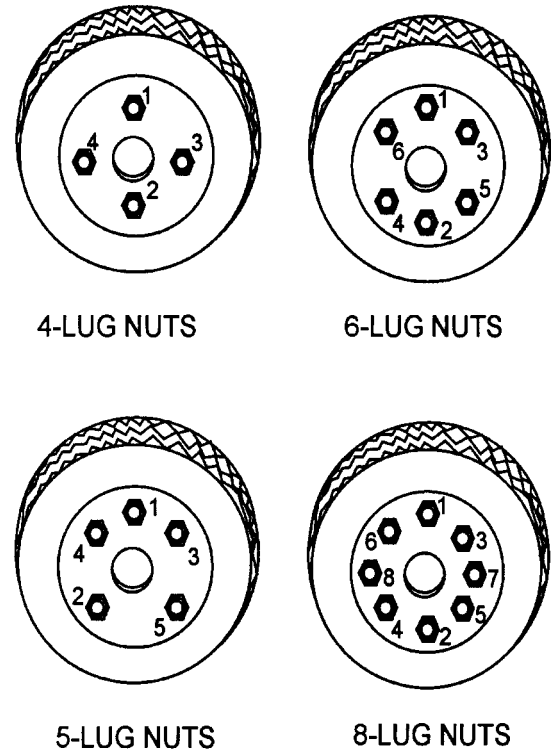

Figure 5. Wheel Lug Nuts Tightening Sequence

NOTE

NEVER use an pneumatic air gun to tighten wheel lug nuts.

TYPICAL 7 POLE TRAILER WIRE DIAGRAM

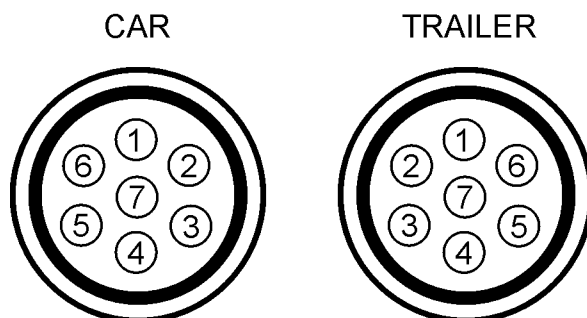

TABLE 5. TRAILER WIRE DIAGRAM

POLE	DESCRIPTION	COLOR
1 / L	LEFT TURN	YELLOW
2 / 54G	REVERSE	BLACK
3 / 31	EARTH	WHITE
4 / R	RIGHT TURN	GREEN
5 / 58R	SERVICE BRAKES	BLUE
6 / 54	STOP LAMP	RED
7 / 58L	TAIL LAMPS	BROWN

DCA-500SSK —TRAILER BRAKE TROUBLESHOOTING

Table 6. Air Brake Troubleshooting

Symptom	Possible Cause	Solution
No Brakes	Brake line broken or kinked?	Repair or replace.
Weak Brakes or Brakes Pull to One Side	Brake lining glazed?	Reburnish or replace.
	Trailer overloaded?	Correct weight.
	Brake drums scored or grooved?	Machine or replace.
	Tire pressure correct?	Inflate all tires equally.
	Tires unmatched on the same axle?	Match tires.
Locking Brakes	Brake components loose, bent or broken?	Replace components.
	Brake drums out-of-round?	Replace.
Noisy Brakes	System lubricated?	Lubricate.
	Brake components correct?	Replace and correct.
Dragging Brakes	Brake lining thickness correct or in right wrong position?	Install new shoes and linings.
	Enough brake fluid or correct fluid?	Replace rubber parts fill with dot4 fluid.

DCA-500SSK — OPERATION AND SAFETY DECALS

Machine Safety Decals

The DCA-500SSK generator is equipped with a number of safety decals. These decals are provided for operator safety and maintenance information. The illustrations below and on the preceding pages shows the decals as they appear on the machine. Should any of these decals become unreadable, replacements can be obtained from your dealer.

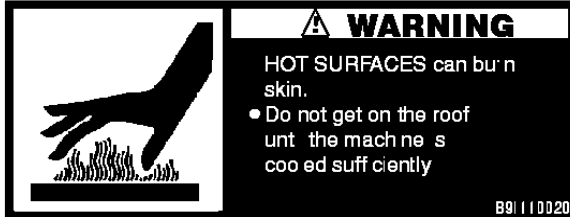

P/N B9511100204

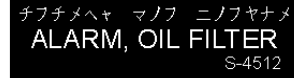

P/N0840655604



P/N 0800686004



P/N 0966810000

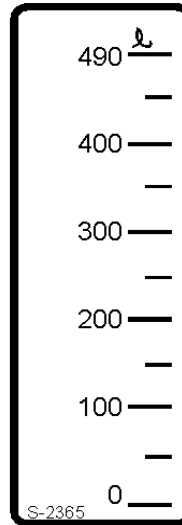

P/N 0840607104



P/N 0800688404



P/N 0800688504

CAUTIONS AGAINST OIL AND FUEL INFILTRATION!

Should oil or fuel infiltrate into the internal sound-absorbing materials, it will cause trouble. Strictly observe the following to keep the machine interior constantly clean:

FUEL
 Feed : Exercise care not to spill oil.
 Air vent : Apply a piece of cloth or similar material to safeguard against fuel infiltration.
 Filter cleaning:
 When detaching the filter for cleaning, apply a piece of cloth or similar material to prevent fuel from dripping.

Oil
 Feed : Exercise care not to spill oil.
 Filter cleaning:
 When detaching the filter for cleaning, apply a piece of cloth or similar material to prevent oil from dripping.

Denyo Co., Ltd. S-544A

P/N 0800615102

DCA-500SSK — OPERATION AND SAFETY DECALS

SAFETY INSTRUCTIONS

Improper operation of this machine can cause severe injury or death.

- Read the instruction manual carefully before operating or servicing.

This machine should only be operated by a person with sufficient knowledge and skill to ensure safe operation.

High voltage circuits are located inside the output terminal cover and control panel.

- Close the cover and control panel before operating.

Moving parts and hot surfaces are contained within the enclosure.

- Close all doors and lock them before operating.

B92110040

P/N B9521100404

ENGINE SPEED

S-4452

P/N 9039208704

HIGH



LOW

S-4451

P/N 9039208694

WHISPERWATT 600



MQ POWER CORP.

WHISPERWATT 600

600 KVA AC GENERATOR

MODEL DCA-600SSK

C56110090

TERMINAL COVER STOPPER



ラネナホ テマヨナメ ノモ
テフマモナ マメ ヘマヨノホヌ

← WHEN COVER IS
CLOSE OR MOVING

ラネナホ テマヨナメ ノモ
マミナホ

← WHEN COVER IS
OPEN

S-4516

P/N 0840655704

COOLING WATER

テママフノホヌ ラチヤナメ
ツナ モユメナ ヤマ マミナメチヤナ ヤネノモ ヘチチネノホナ ラノヤネ ノヤモ
メチトノチヤマメ テチミ テマヘミフナヤナフル モナチユメナトヨ メナミフチチナ
ヤネナ テチミ ラノヤネ チ ホナラ マホナ ラネナホ トチヘチヌナトヨ

Be sure to operate this machine with its radiator cap completely secured. Replace the cap with a new one when damaged or deformed.

S-961

P/N 0800689204

Precautions on handling the oil drain pump

(1) Handling procedures

Connect an oil-discharging hose to the the "OUT" side of the pump and turn on the battery switch. Remove the plug from the pump and feed priming oil. Then, turn on the pump main body switch and drain oil from the oil pan.

(2) Precautions

1. Operate the pump only after feeding a sufficient amount of priming oil; do not idle the pump. Use the priming oil of the same kind with that to be pumped up.
2. The rating of the pump is 25 minutes.
Do not operate the pump continuously over that value.
3. Always keep the main body switch OFF unless replacing oil.

S-2570

P/N 0840611903

DCA-500SSK — OPERATION AND SAFETY DECALS



P/N 08006 89404

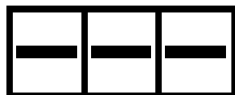

P/N 08006 89504

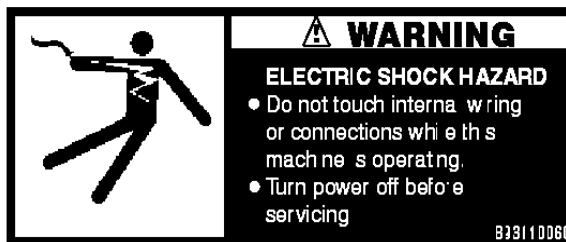

P/N B931100604

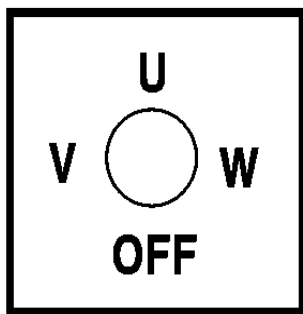

P/N 0800520904

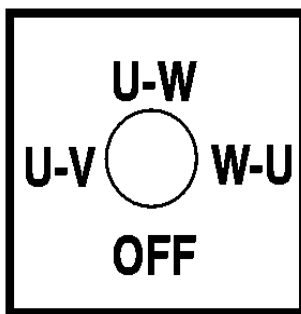

P/N 0800520814

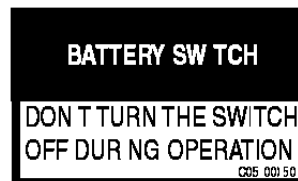

P/N C0551000704



P/N 0840624604

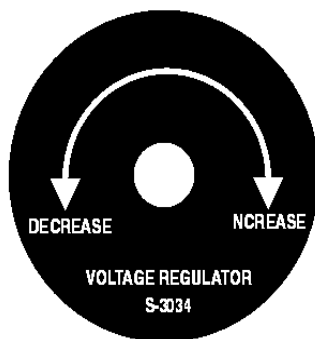

P/N 0840624804



P/N 08406 24504

PREHEAT LAMP

S-3036

P/N 0840625004

DCA-500SSK — OPERATION AND SAFETY DECALS

**CIRCUIT
BREAKER**

S-3031

P/N 08406 24504



P/N 0840625902

SUPPORT HOOK

Never use it for lifting the unit.
Use the LIFT HOOK on the roof for lifting.

S-2257

P/N 13206 21504

WATER • OIL CHECK AND FILL DAILY

C0511004

P/N C0551000404

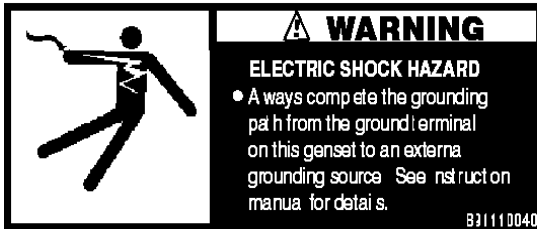

P/N B9511100404

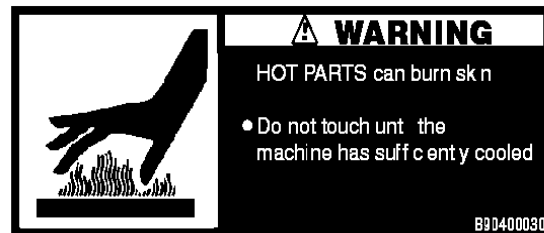

P/N B9504000304



P/N B9504100104



P/N B9504500004

DIESEL FUEL
S-1756

P/N 1320620904

**FUEL
DRAIN PLUG** ↓
S-1883

P/N 6360620004

DCA-500SSK — OPERATION AND SAFETY DECALS

	WARNING
	<ul style="list-style-type: none"> ● Only operate machine in well ventilated areas. ● Do not inhale exhaust gases.
DANGEROUS GAS	Only qualified personnel should install, use, or service this equipment.

P/N B950420004

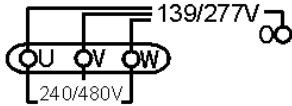
<p>3-Phase output terminal</p> <p>Keep the loads balancing when using plural single loads.</p>	
	C05100040

P/N C0551000404

GROUND

S-2635

P/N 0840614104

	WARNING
	<p>ELECTRIC SHOCK HAZARD</p> <ul style="list-style-type: none"> ● Always complete the grounding path from the ground terminal on this genset to an external grounding source. See instruction manual for details.
	B91110040

P/N B9511100404

WARNING
<ul style="list-style-type: none"> ● Before connecting this generator to any building's electrical system, a licensed electrician must install an isolation (transfer) switch. ● Serious injury or death may result without this transfer switch.
B91110030

P/N B9511100304

	WARNING
	<p>ELECTRIC SHOCK HAZARD</p> <ul style="list-style-type: none"> ● Do not touch output terminals while this machine is operating. ● Turn power off before servicing.
	B31110050

P/N B9531100504

DCA-500SSK — SPECIFICATIONS

Table 7. Specifications

Generator Specifications		
Model	DCA-500SSK	
Type	Revolving field, self-ventilated, 4-pole, drip-proof, single bearing	
Excitation	Brushless with AVR	
Phase	3	
Standby Output	440KVA (550 KW)	
Prime Output	400 KVA (500 KW)	
Voltage	208,220,240,416,440,480 reconnectable (3 phase) 120,127,139,240,254,277 adjustable (single phase)	
Frequency	60 Hz	
Speed	1800 rpm	
Power Factor	0.8	
Sound Level dB(A)	69 (full load at 23 feet)	
Engine Specifications		
Model	KOMATSU SA6D170BE	
Type	direct injection, turbo-charged with after-cooler	
No. of Cylinders	6 cylinders	
Bore x Stroke	6.8 in. x 6.8 in. (170 mm x 170 mm)	
Rated Output	572 HP/1800 rpm	
Displacement	1411.5 cu. in. (23150 cc)	
Starting	Electric	
Coolant Capacity	31.4 gal. (118.8 liters)	
Lube Oil Capacity	28.5 gal. (108 liters)	
Fuel Consumption	29 gal. (109.7L)/hr at full load	22.3 gal. (84L)/hr at 3/4 load
	16.5 gal. (62L)/hr at 1/2 load	10.6gal/(40L)/hr at 1/4 load
Battery	12V- 200 AH x 2 (24 Volt system)	
Fuel	#2 Diesel Fuel	

DCA-500SSK FAMILIARIZATION

Generator

The MQ Power Model DCA-500SSK is a 550 kW **generator** that has been designed as a high quality portable (requires a trailer for transport) power source for telecom sites, lighting facilities, power tools, submersible pumps and other industrial and construction machinery.

Engine Control Panel

The “Engine Control Panel” is provided with the following:

- Tachometer
- Water Temperature Gauge
- Oil Pressure Gauge
- Charging Ammeter Gauge
- Engine Warning Lamp Module
- Throttle Lever
- Engine Speed Switch
- Pre-Heat Button
- Pre-Heat Lamp
- Emergency Stop Button
- Battery Switch

Generator Control Panel

The “Generator Control Panel” is provided with the following:

- Output Voltage Adjustment Knob
- Frequency Meter (Hz)
- AC Ammeter (Amps)
- AC Voltmeter (Volts)
- Ammeter Change-Over Switch
- Voltmeter Change-Over Switch
- Panel Light
- Panel Light Switch
- MPEC Module
- Pilot Lamp

Microprocessor Controlled Alarm System

The DCA-500SSK generator is equipped with various alarms and LED status indicators. These alarms and status indicators are provided to add safety to the generator when operating under normal conditions. The DCA-500SSK generator is designed to shutdown in the event of low oil, high coolant temperature, low battery and other operation conditions that may cause severe damage to the generator.

Open Delta Excitation System

The DCA-500SSK generator is equipped with the state of the art “**Open-Delta**” excitation system. The open delta system consist of an electrically independent winding wound among stationary windings of the AC output section.

There are four leads: A, B, C and D. During light loads, the power to the **Automatic Voltage Regulator** (AVR) is supplied from the leads parallel connections of B&C. When loads increase, the AVR switches and accepts power from leads A&D. The output of leads A&D increase proportionally with load. This of adding the voltages to each phase provides better voltage response during heavy loads.

The connections of the AVR to the AC output windings are for sensing only. No power is required from these windings.

The open-delta design provides virtually unlimited excitation current, offering maximum motor starting capabilities. The excitation does not have a “**fixed ceiling**” and responds according the demands of the required load.

Engine

The **DCA-500SSK** is powered by a 4 cycle, water cooled, turbocharged KOMATSU Model SA6D170BE diesel engine. This engine is designed to meet every performance requirement for the generator. Reference Table 7, page 23 for engine specifications.

In keeping with MQ Power's policy of constantly improving its products, the specifications quoted herein are subject to change without prior notice.

The basic controls and indicators for the DCA-500SSK generator are addressed on the following pages.

Electronic Governor System

The electronic governor system is made up of two parts, an electronic controller that monitors frequency variation as the load increases and decreases, and an electronic actuator that controls the engine throttle. The frequency is regulated at ± 0.25 to help protect sensitive equipment.

DCA-500SSK — MAJOR COMPONENTS

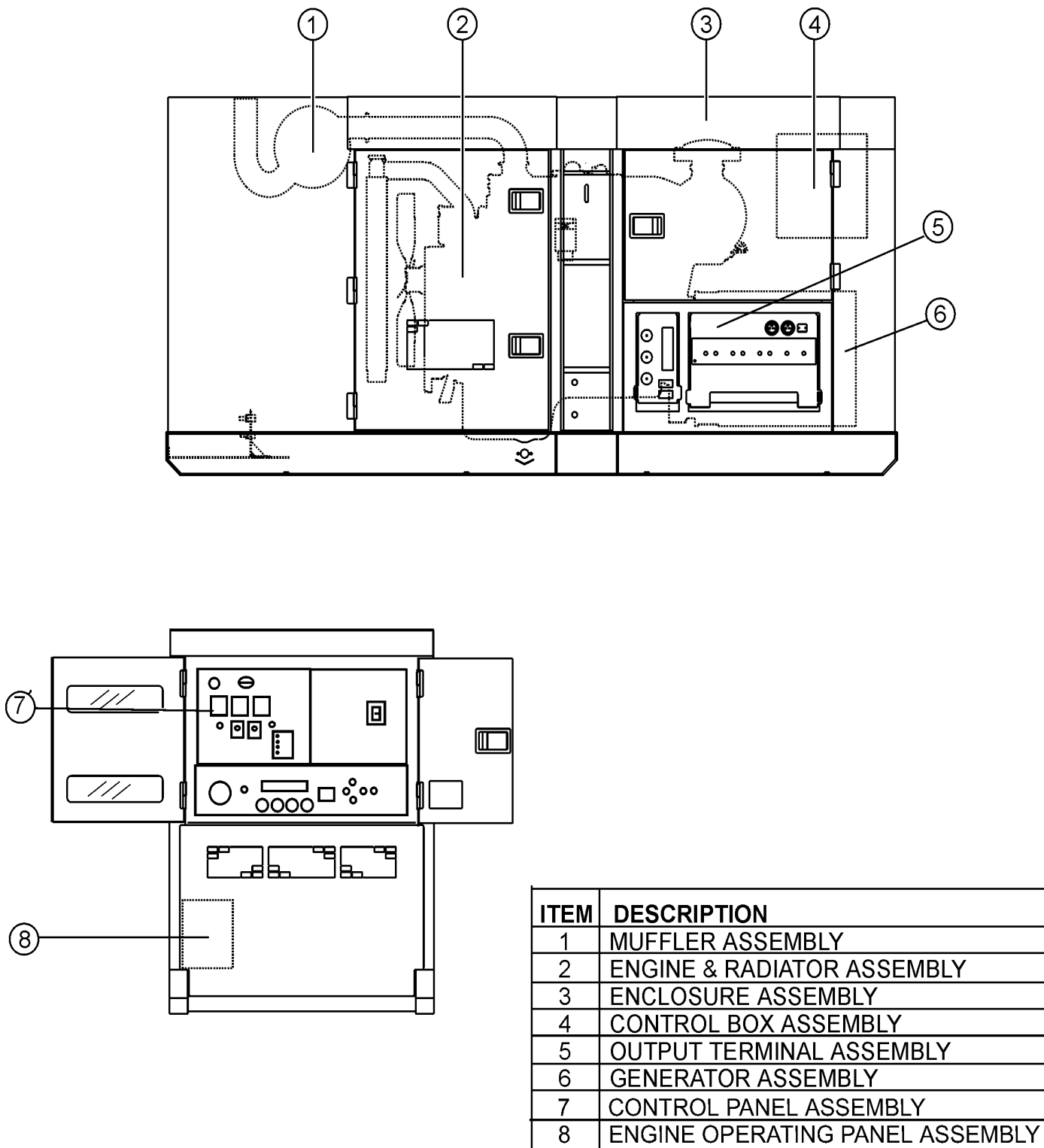
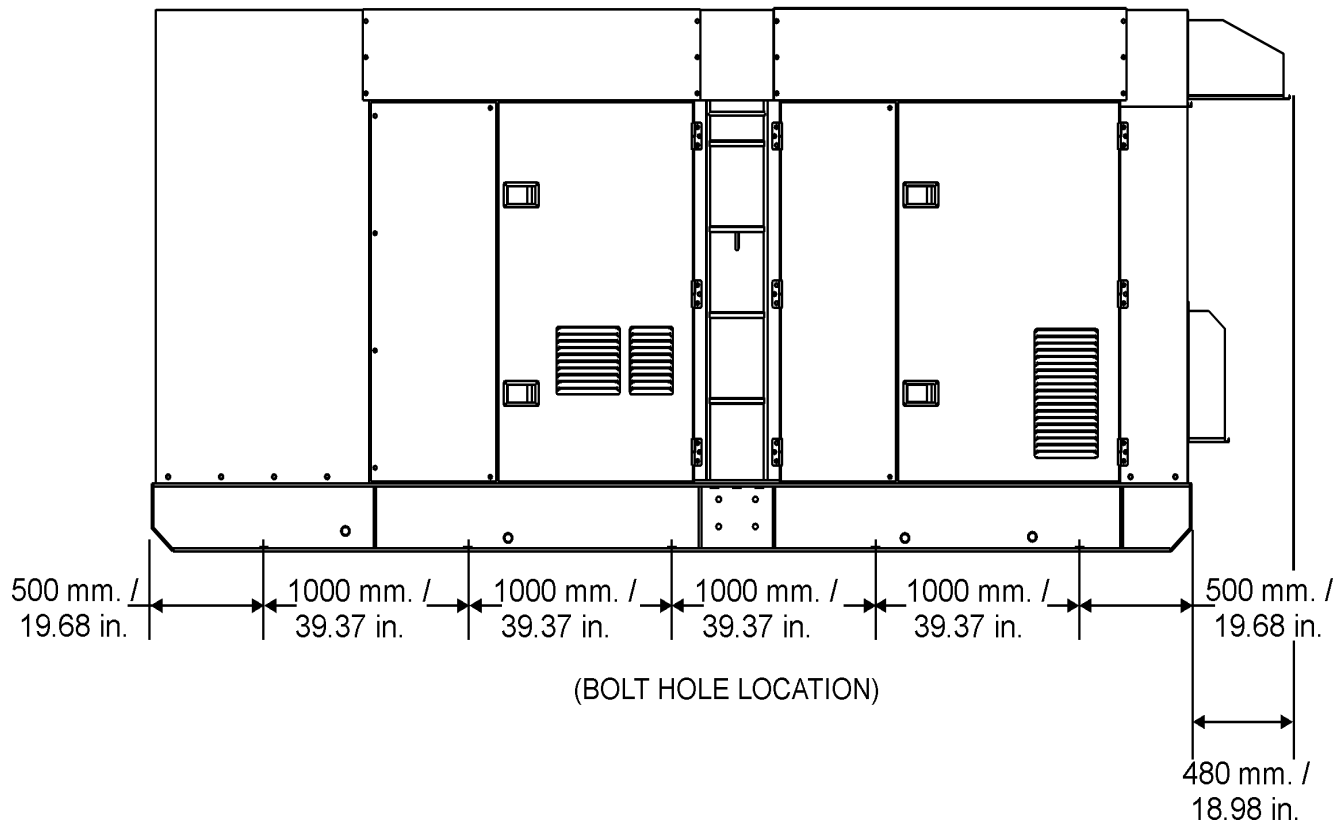

Figure 6. Major Components

DCA-500SSK — DIMENSIONS (TOP AND SIDE)

SIDE VIEW



TOP VIEW

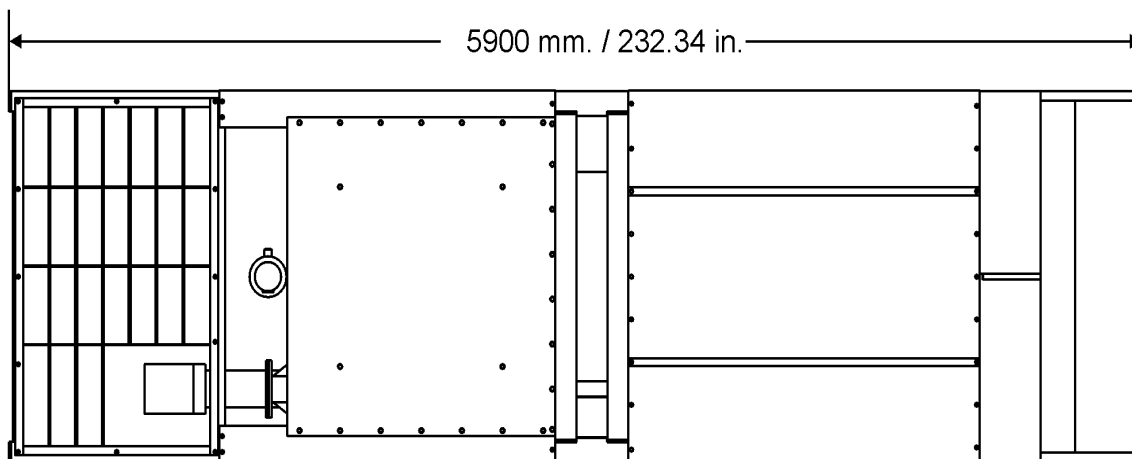

Figure 7a. Dimensions

DCA-500SSK — DIMENSIONS (FRONT AND REAR)

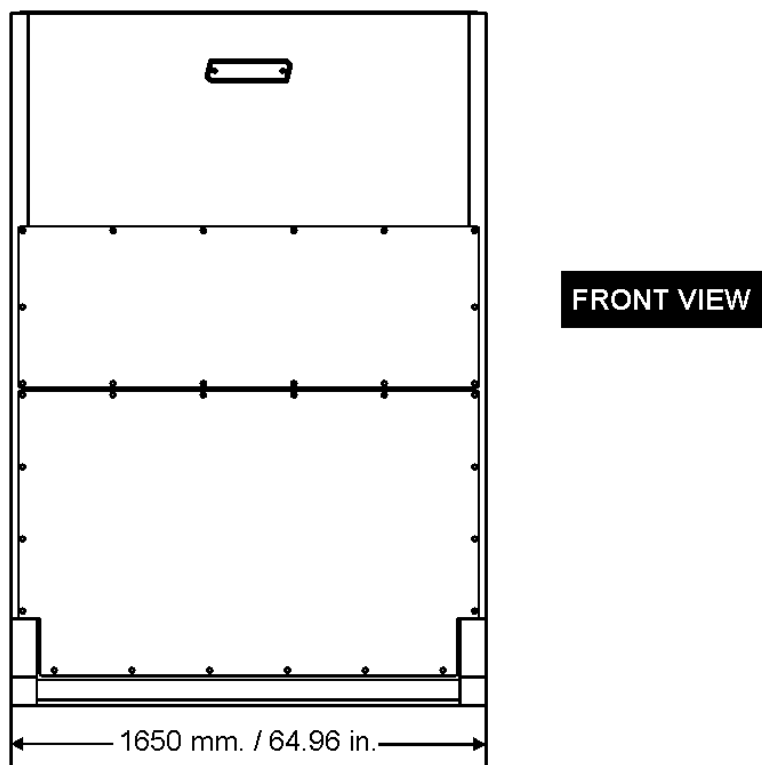
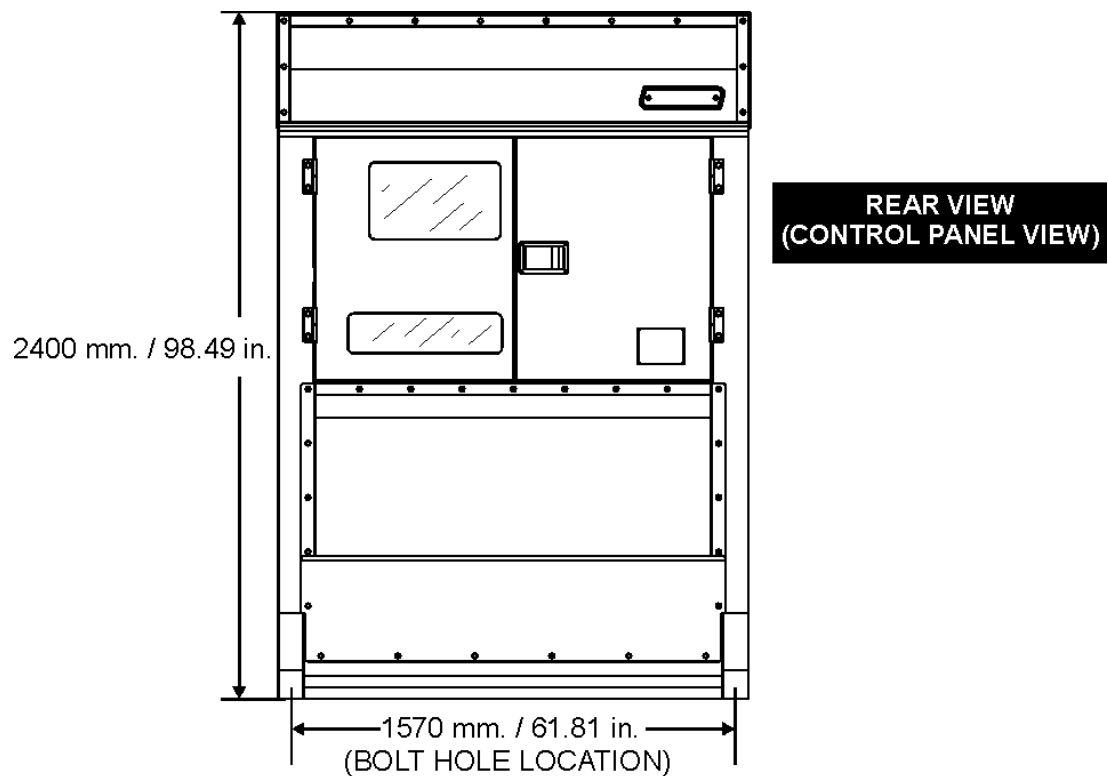
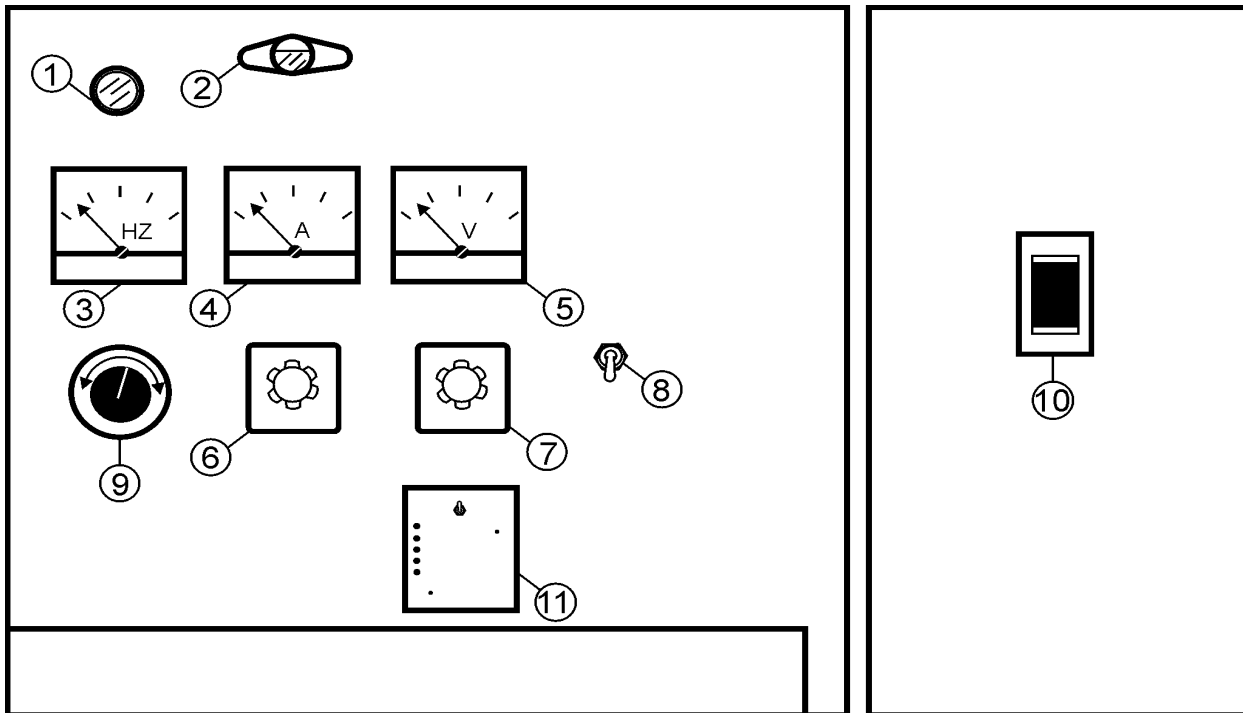

Figure 7b. Dimensions



NO.	NAME
1	PILOT LAMP
2	PANEL LIGHT
3	FREQUENCY METER
4	AC AMMETER
5	AC VOLTMETER
6	AMMETER CHANGE OVER SWITCH
7	VOLTMETER CHANGE OVER SWITCH
8	LIGHT PANEL SWITCH
9	VOLTAGE REGULATOR
10	CIRCUIT BREAKER
11	MPEC MODULE

Figure 8. Control Panel

The definitions below describe the controls and functions of the DCA-500SSK " **Control Panel** " (Figure 8).

1. **Pilot Lamp** – Indicates that the generator is working properly.
2. **Panel Light** – Normally used in dark areas or at night time. When activated, panel lights will illuminate. When lit this light will make it easier to read the meters and gauges. When the generator is not in use be sure to turn the panel light switch to the OFF position.
3. **Frequency Meter** – Indicates the output frequency in hertz (Hz). Normally 60 Hz \pm 1 Hz .
4. **AC Ammeter** – Indicates the amount of current the load is drawing from the generator.
5. **AC Voltmeter** – Indicates the single phase output voltage present at the UVW terminals. .
6. **Ammeter Change-Over Switch** – This switch allows the AC ammeter to indicate the current flowing to the load connected to any phase of the output terminals, or to be switched off.
7. **Voltmeter Change-Over Switch** – This switch allows the AC voltmeter to indicate phase to phase voltage between any two phases of the output terminals or to be switched off
8. **Panel Light Switch** – When activated, this switch will turn on the luminate the control panel.
9. **Voltage Regulator Control** – Allows manual adjustment of the generator's output voltage
10. **Main Circuit Breaker** – This three-pole, 1400 amp main breaker is provided to protect the UVW voltage output terminals from overload.

11. **MPEC – Microprocessor Engine Control Module** – (MPEC) has a vertical row of status LED's (Figure 9), that when lit, indicate that an engine malfunction (fault), has been detected. When a fault has been detected the MPEC will evaluate the fault and if the fault is major will shutdown the generator.

During **cranking cycle**, The MPEC will attempt to crank the engine for 10 seconds before disengaging.

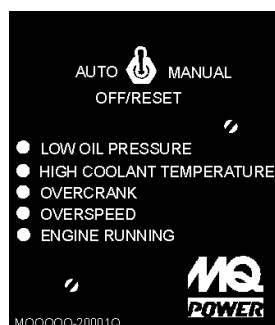

Figure 9. MPEC Module

If the engine does not engage (start) by the third attempt, the engine will be shutdown by the MPEC's " Over Crank Protection" mode. If the engine engages at a speed (RPM's) that is not safe, the MPEC will shutdown the engine by initializing the "Over Speed Protection" mode.

Also the MPEC will shutdown the generator in the event of low oil pressure, high coolant temperature, low coolant level, and loss of magnetic pickup. These conditions can be observed by monitoring the LED status indicators on the front of the MPEC module.

- A. **Off/Manual/Auto Switch** – This switch controls the running of the generator. If this switch is left in the "OFF" position, the generator will not run. When this switch is set to the **manual** position, the generator will start immediately.

If the generator is to be connected to a building's AC power source via a transfer switch (isolation), place the switch in the **auto** position. In this position the generator will monitor the AC line output from the building's power source. The generator will engage when commercial power falls below a preset level.

- B. **Low Oil Pressure** – Indicates the engine pressure has fallen below 15 psi. The oil pressure is detected using variable resistive values from the oil pressure sending unit. This is considered a **major** fault and will shut down the generator.
- C. **High Coolant Temperature** – Indicates the engine temperature has exceeded 215°F. The engine temperature is detected using variable resistive values from the temperature sending unit. This is considered a **major** fault and will shut down the generator.
- D. **Overcrank Shutdown** – Indicates the unit has attempted to be started a pre- programmed number of times, and has failed to start. The number of cycles and duration are programmable. Typical programmable start settings is 3 cycles with a 10 second duration. This is considered a **major** fault and will shut down the generator.
- E. **Overspeed Shutdown** – Indicates that the engine is running at an unsafe speed. This is considered a **major** fault.
- F. **Engine Running** – Indicates that engine is running at a safe operating speed.

DCA-500SSK — ENGINE OPERATING PANEL

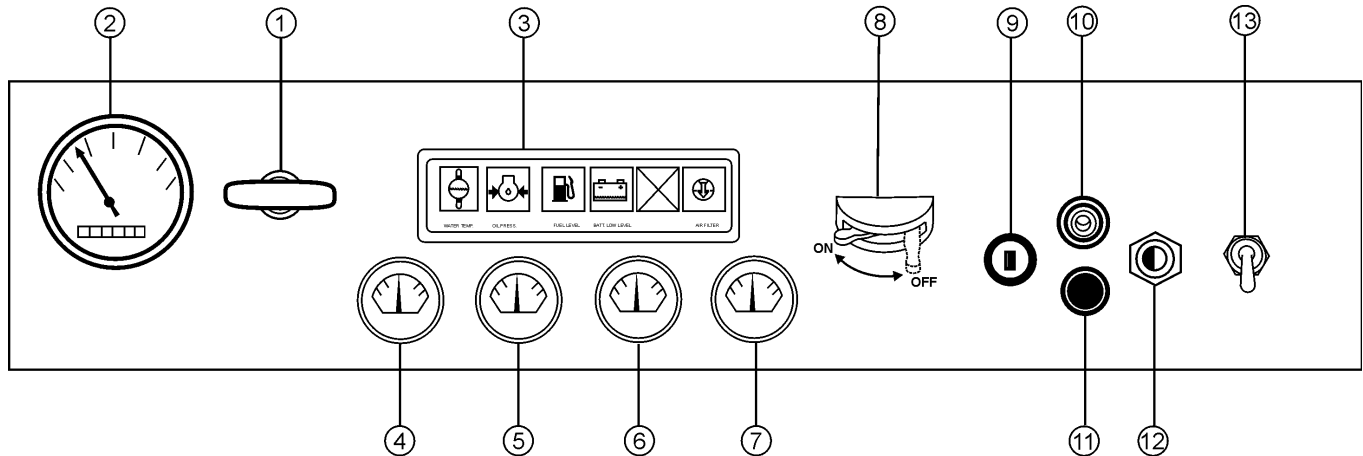

1	THROTTLE HANDLE
2	TACHOMETER
3	ENGINE WARNING DISPLAY LED
4	OIL PRESSURE GAUGE
5	WATER TEMP. GAUGE
6	CHARGING AMMETER
7	FUEL LEVEL GAUGE
8	BATTERY SWITCH
9	STARTER SWITCH
10	PREHEAT LAMP
11	PREHEAT BUTTON
12	EMERGENCY STOP BUTTON
13	ENGINE SPEED SWITCH

Figure 10. Engine Operating Panel

DCA-500SSK — ENGINE OPERATING PANEL

The definitions below describe the controls and functions of the DCA-500SSK " **Engine Operating Panel** " (Figure 10).

1. **Throttle Handle**- Use this handle to adjust the RPMs when the engine is idling (no load).
2. **Tachometer** – Indicates engine speed in RPM's for 60 Hz operation. This meter should indicate 1800 RPM's when the rated load is applied. In addition a built in hour meter will record the number of operational hours that the generator has been in use.
3. **Engine Warning Display (LED) Module** – This module display's the following engine failures:

A. **Overheat Lamp** – This lamp goes ON when the cooling water temperature rises abnormally. If the lamp goes ON during normal operation of the generator, the emergency shutdown device will stop the engine automatically.

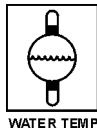

B. **Low Oil Pressure Lamp** – During normal operation of the generator this lamp should remain OFF. When the Auto-OFF/Reset-Manual switch is set to the "Manual" position to start the engine, the lamp will illuminate. After the oil pressure rises after start-up the lamp will go OFF. If this lamp is ever illuminated (ON) during normal operation of the generator, the emergency shutdown device will stop the engine automatically.



C. **Low Fuel Level Lamp** – When this lamp is ON, it is time to stop the engine and add fuel. Remember to let the engine cool before adding fuel.

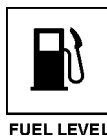

D. **Low Battery Fluid Lamp** – This lamp goes ON when the battery fluid is low. If this lamp goes ON during normal operation of the generator, stop the engine and fill the battery with distilled water to the specified level.

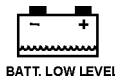

E. **Clogged Air Filter Lamp** – This lamp goes ON when the air filter is clogged. If this lamp goes ON during normal operation of the generator, stop the engine and replace the air filter.

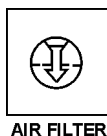

4. **Oil Pressure Gauge** – During normal operation this gauge be should read in the "GREEN" zone. When starting the generator the oil pressure mar read a little bit higher, but after the engine warms up the oil pressure should return to the green zone.
5. **Water Temperature Gauge** – During normal operation this gauge be should read in the "GREEN" zone.
6. **Charging Ammeter Gauge** – Indicates the current being supplied by the engine's alternator which provides current for generator's control circuits and battery charging system.
7. **Fuel Level Gauge** – Indicates amount of diesel fuel remaining.

8. **Battery Switch** – This switch should be set to the ON position during normal operation. When the engine has been stop, place this switch in the OFF position. **DO NOT** turn this switch during normal operation, it could cause damage to the electrical equipment

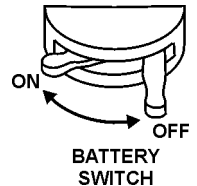

9. **Ignition Switch**- Use this switch to start the engine in manual mode (see instructions on starting generator.)

10. **Pre-Heat Lamp** – Indicates that the glow plugs of the diesel engine are hot and the engine is ready to be started.



11. **Preheat Switch** – Turn this switch on to heat diesel engine in cold weather conditions.

12. **Emergency Stop Button** – Push this button inward to stop the engine in the event of an emergency. **DO NOT** use this button as a normal means of stopping the engine.

13. **Engine Speed Switch** – This switch changes the engine speed from idle to normal.

600SSK FAMILIARIZATION

The "Output Terminal Panel" is provided with the following:

- Two 120V GFCI receptacles, 20 amp
- Three 240/139V output receptacles, 50 amp
- Two 120V input receptacles, 20 amp (optional)
- 3 Load Circuit Breakers 265V @65 amps
- 2 Load GFCI Circuit Breakers 265V @ 20amps

Control Box

The "Control Box" is provided with the following:

- Main Circuit Breaker 1400 amps
- Over-Current Relay

Output Terminal Panel

The Output Control Panel (See Figure 14) is located on the right hand side (left from control panel) of the generator. The UVWO lugs are protected by a face plate cover that can be secured in the close position by a pad lock. (See Figure 11).

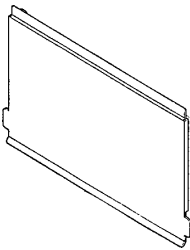

Figure 11. Output Terminal Cover

120 Volt Recetacle

Two GFCI Duplex Nema 5-20R (120V, 20 Amp) receptacle is provided on the output terminal. This receptacle can be used anytime the generator is in operation. The receptacle is controlled by the circuit breaker located on the control panel.

Pressing the reset button resets the receptacle after being tripped. Pressing the "Test Button" (See Figure 12) in the center of this receptacle will check the GFCI function. The receptacle should be tested at least once a month.

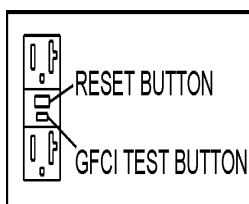

Figure 12. GFCI Test/Reset Button

Connecting Load

Loads can be connected to the generator by the UVWO Lugs or the convenience receptacles. (See Figure 13). Make sure to read the operation manual before attempting to connect a load to the generator.

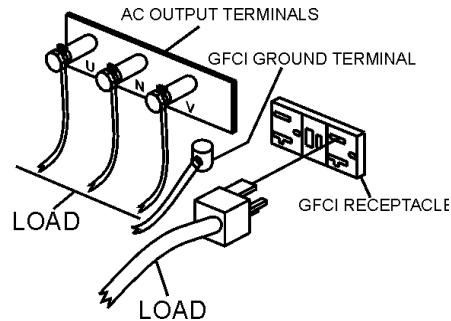

Figure 13. Connection Receptacles

Circuit Breakers

To protect the generator from an overload, a 3-pole, 1400 amp, **main** circuit breaker is provided to protect the UVWO output terminals from overload. In addition two single-pole, 20 amp **GFCI** circuit breakers are provided to protect the GFCI receptacles from overload. Three 50 amp **load** circuit breakers have also been provided to protect the load side of the generator from overload. **Make sure to switch ALL** circuit breakers to the "OFF" position prior to starting the engine.

Maximum Output

The entire load connected to the UVWO Lugs, all four slots in the duplex receptacles, and the must not exceed 500 kW in standby or 550 kW in prime output.

Twist Lock Dual Voltage Receptacles

Three CS-6369 auxiliary power receptacles have been provided to supply 208/120V. The voltage regulator knob on the control panel may need to be used to adjust the voltage to 208 or 416V.

Input Receptacles

Two 120 volt, 20 amp input receptacles are provided to supply power to accessories, such as the battery charger (optional) or jacket water heater (optional).

DCA-500SSK — OUTPUT TERMINAL

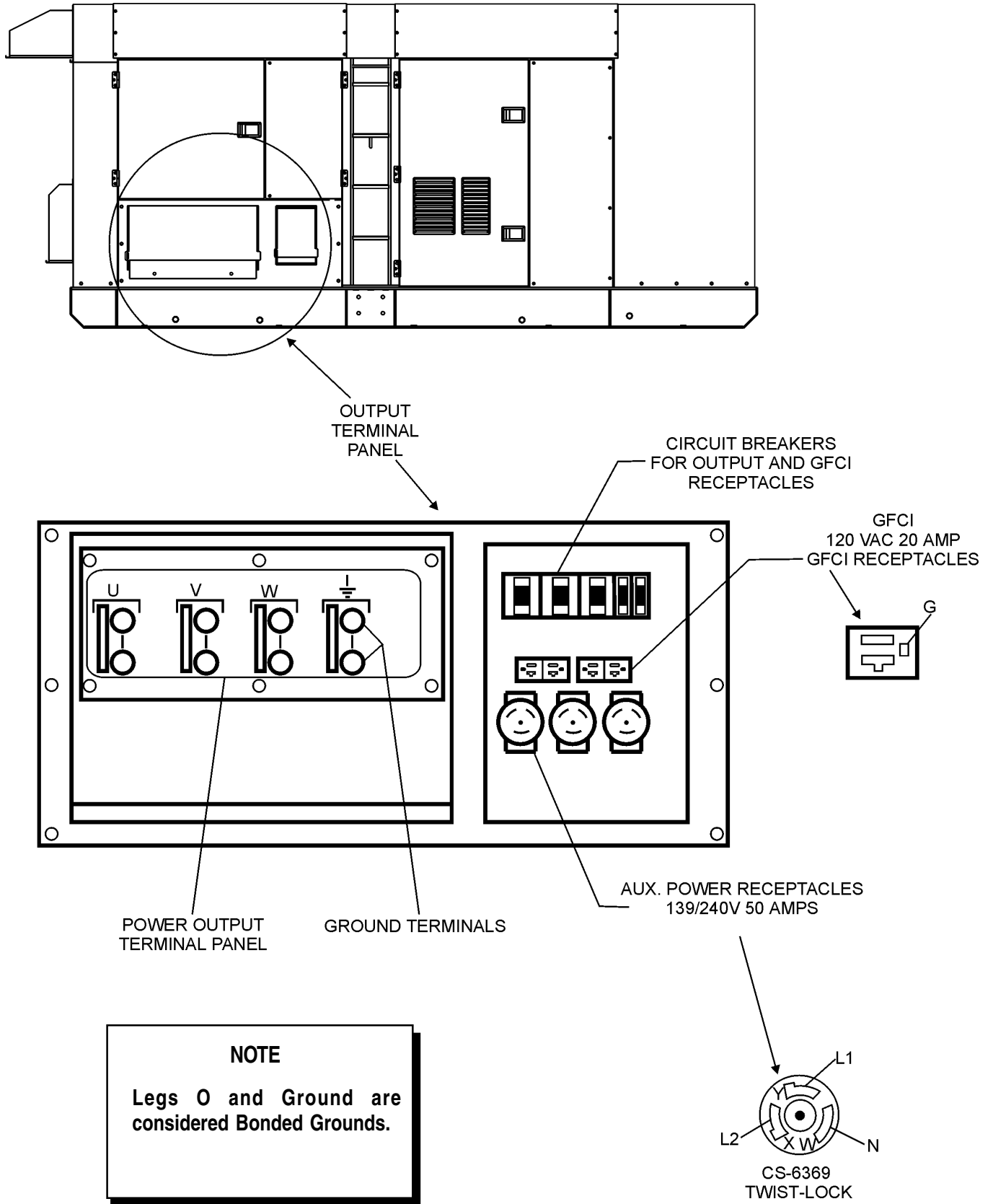

Figure 14. Output Terminal Panel Location

DCA-500SSK — OUTPUT TERMINAL

Output Terminal Panel Available Voltages

A wide range of voltages are available to supply load to many different applications. Voltages may be selected by using the voltage change-over board and how to hookup the hard wire connection to the voltages listed, fine adjustment with the Voltage Regulator on the control panel is necessary. See the table below (Table 8) for a list of available voltages the generator is able to supply.

CAUTION:



NEVER attempt to change the Voltage Change-Over Board with the engine is running.

TABLE 8. VOLTAGES AVAILABLE

MODEL	DCA500SSK					
3 PHASE VOLTAGE (RECONNECTABLE)	208 VOLT	220 VOLT	240 VOLT	416 VOLT	440 VOLT	480 VOLT
SINGLE PHASE (ADJUSTABLE)	120 VOLT	127 VOLT	139 VOLT	240 VOLT	254 VOLT	277 VOLT

Over Current Relay

An over current relay is connected to the circuit breaker. During an over current situation, both the circuit breaker and the over current relay may trip. If the circuit breaker can not be reset, the reset button on the over current relay must be pressed. The over current relay is located on the control box.

Maximum Amps

The following table below shows the maximum amps the generator can provide **Do not exceed the maximum amps listed below.**

Table 9. Maximum Amps	
Model:	DCA500SSK
Rated Voltage	Maximum Amps
Single Phase 120 Volt	1111.1 amps (4 wire)
Single Phase 240 Volt	555.6 amps (4 wire)
Three Phase 240 Volt	1202.8 amps
Three Phase 480 Volt	601.4 amps

Reading the Output Terminal Gauges

The gauges and knobs on the control panel **DO NOT** effect the generator output. They are to help the operator observe how much power supply is produced at the UVWO legs.

To read the output at the U-W legs, place the AC Voltmeter Change-over switch to the W-U position and the AC ammeter Change-over Switch to the U or W position to read the output on the selected leg.

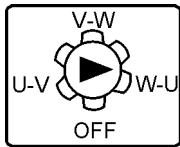

Figure 15. AC Voltmeter Change-Over Switch (Reading the W-U leg on the output terminal Panel)

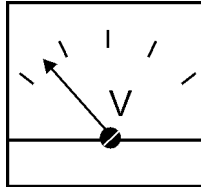

Figure 16. AC Voltmeter Gauge (Voltage reading on W-U lug)

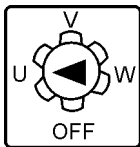

Figure 17. AC Ammeter Change-Over Switch (Reading the W-U leg on the output terminal Panel)

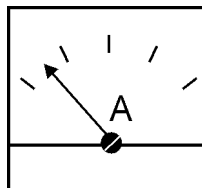

Figure 18. AC Ammeter Gauge (Amp reading on U lug)

Voltage Change-over Board

The voltage change-over board changes the available voltages of the output terminal panel UVWO lugs. The voltage change-over board is located on the control box behind the control panel. There are six (6) plates that can be set into two set positions to get six different voltages. Unless specified differently, the generator comes from the factory in the 240V position.

240 Volt Set position

The voltage change-over board 240V set position uses all 6 plates in 6 different connection places. See figure 19 below.

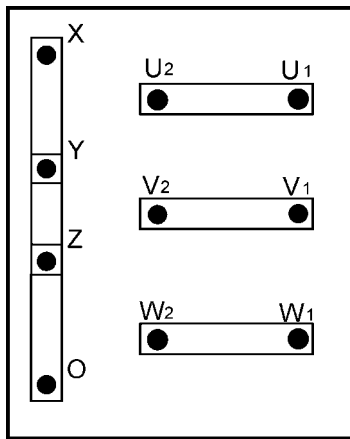

FIGURE 19. Voltage Change-over Board 240V set position.

3 Phase, 240 Volt

The following connection, with the voltage change-over board set into the 240V set position (See Figure 19), can offer **THREE PHASE** power at 240V. After hooking up the hard wires to the lugs as shown in figure 20 below, 240V will be the voltage output.

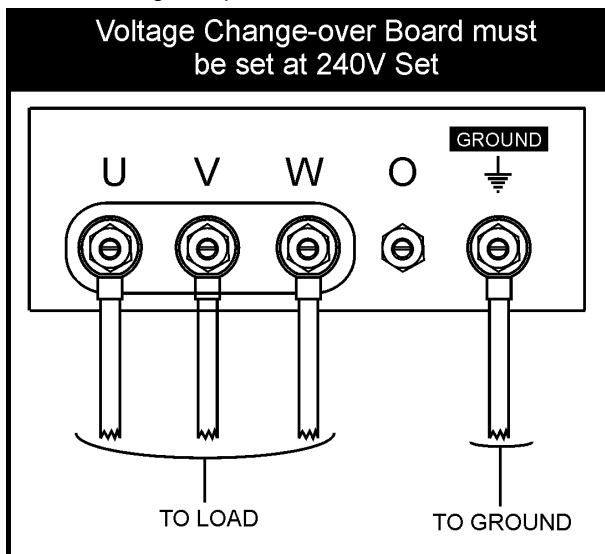

FIGURE 20. Hard Wire Hookup for Three Phase 240V

Single Phase, 240 Volt

The following connection, with the voltage change-over board set into the 240V set position (See Figure 19), can offer **SINGLE PHASE** power at 240V. After hooking up the hard wires to the lugs as shown in figure 21 below, 240V will be the voltage output.

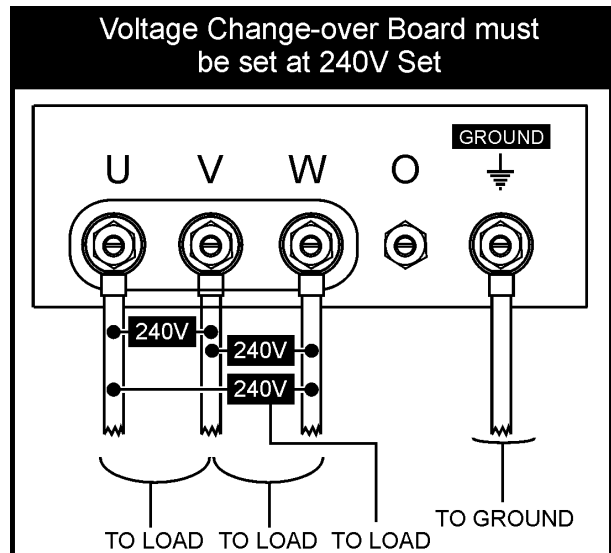

FIGURE 21. Hard Wire Hookup for Single Phase 240V

Single Phase, 139 Volt

The following connection, with the voltage change-over board set into the 240V set position (See Figure 19), can offer **SINGLE PHASE** power at 139V. After hooking up the hard wires to the lugs as shown in figure 22 below, 139V will be the voltage output.

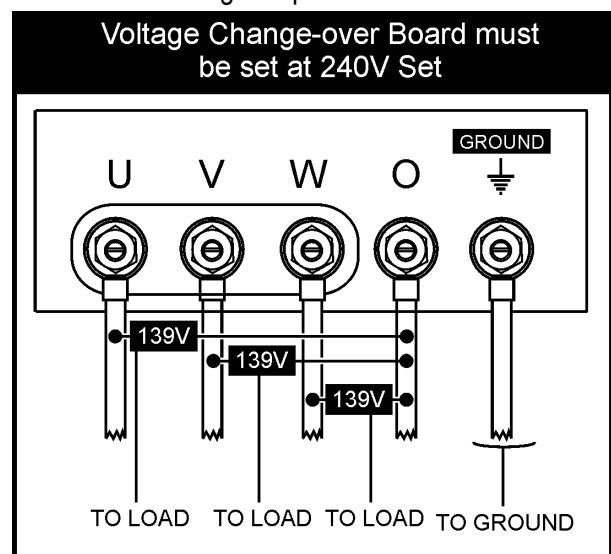

FIGURE 22. Hard Wire Hookup for Single Phase 139V

480 Volt Set position

The voltage change-over board 480V set position uses all 6 plates in 3 different connection places. There are 2 plates at every position (Every plate is used). See figure 23 below.

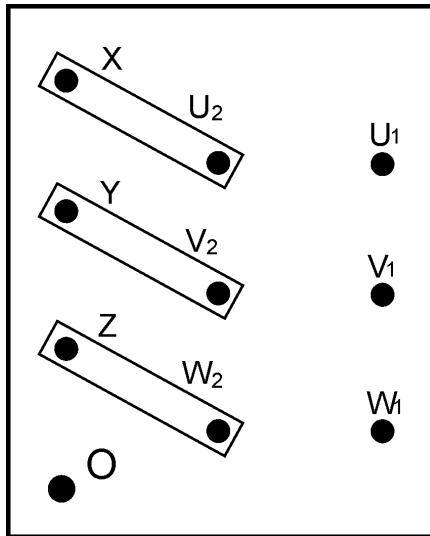

FIGURE 23. Voltage Change-over Board 480V set position.

3 Phase, 480 Volt

The following connection, with the voltage change-over board set into the 480V set position (See Figure 23), can offer **THREE PHASE** power at 480V. After hooking up the hard wires to the lugs as shown in figure 24 below, 480V will be the voltage output.

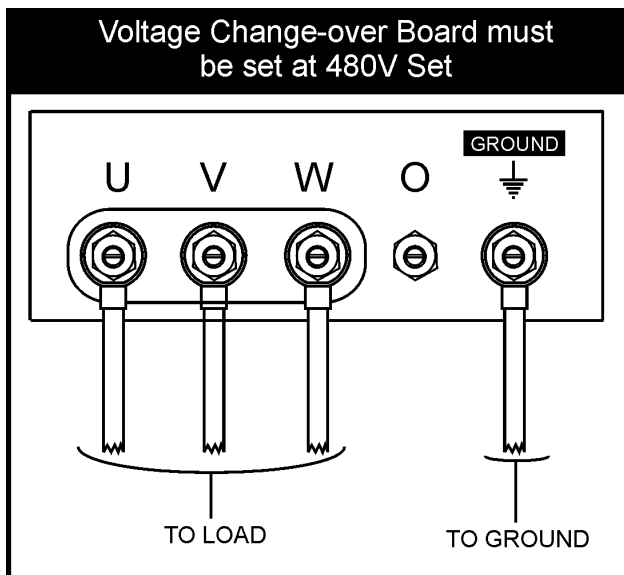

FIGURE 24. Hard Wire Hookup for Three Phase 480V

Single Phase, 480 Volt

The following connection, with the voltage change-over board set into the 480V set position (See Figure 23), can offer **SINGLE PHASE** power at 480V. After hooking up the hard wires to the lugs as shown in figure 25 below, 480V will be the voltage output.

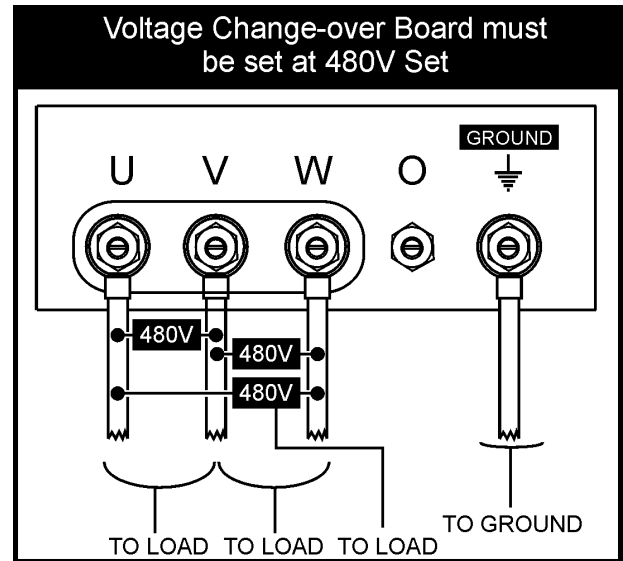

FIGURE 25. Hard Wire Hookup for Single Phase 480V

Single Phase, 277 Volt

The following connection, with the voltage change-over board set into the 480V set position (See Figure 23), can offer **SINGLE PHASE** power at 277V. After hooking up the hard wires to the lugs as shown in figure 26 below, 277V will be the voltage output.

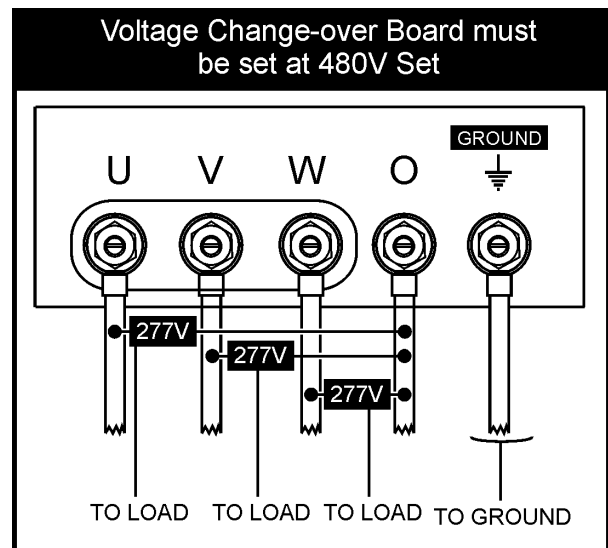

FIGURE 26. Hard Wire Hookup for Single Phase 277V

Outdoor Installation

Install the generator in a location where it will not be exposed to rain or sunshine. Make sure the generator is on secure level ground so that it cannot slide or shift around. Also install the generator in a manner so the exhaust will not be discharged in the direction of nearby homes.

The installation site must be free from excessive moisture and dust. All electrical equipment must be protected from excessive moisture. Failure to do will result in deterioration of the insulation and will result in short circuits and grounding.

Foreign materials such as dust, sand, lint and abrasive materials will cause excessive wear to the engine and alternator parts.

CAUTION :



Pay close attention to ventilation when operating the generator inside tunnels and caves. The engine exhaust contains noxious elements. Engine exhaust must be routed to a ventilated area.

Indoor Installation

Exhaust gases from diesel engines are **extremely** poisonous. If the generator is installed indoors, the exhaust fumes must be vented to the outside. The engine must be installed at least two feet from any outside wall. Using an exhaust pipe that is too long or too small will cause excessive back pressure resulting in engine overheating.

Eliminate the danger of deadly carbon monoxide gas. Exhaust fumes from any diesel engine are very poisonous if discharged in a closed room, but harmless if allowed to mix with the outside air.

CAUTION :

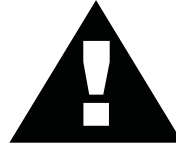

An electric shock will happen when vibrators are used. Pay close attention to handling when operating vibrators and always use rubber boots and gloves to insulate the body from electrical shock.

Generator Grounding

To prevent electrical shock and possible damage to the equipment, it is important to provide a good **EARTH** ground.

Article 250 (Grounding) of the National Electrical Code (NEC) provides guide lines for proper grounding and specifies the cable ground shall be connected to the grounding system of the building as close to the point of cable entry as practical.

NEC articles 250-64(b) and 250-66 set the following grounding requirements:

1. Use one of the following wire types to connect the generator to earth ground.
 - a. Copper - 10 AWG (5.3 mm²) or larger.
 - b. Aluminum - 8 AWG (8.4 mm²) or larger.
2. When grounding the generator (Figure 27) connect the ground cable between the lock washer and the nut on the generator and tighten the nut fully. Connect the other end of the ground cable to earth ground.
3. NEC article 250-52(c) specifies that the earth ground rod should be buried a minimum of 8 ft. into the ground.

NOTE

When connecting the generator to any buildings electrical system **ALWAYS** consult with a licensed electrician.

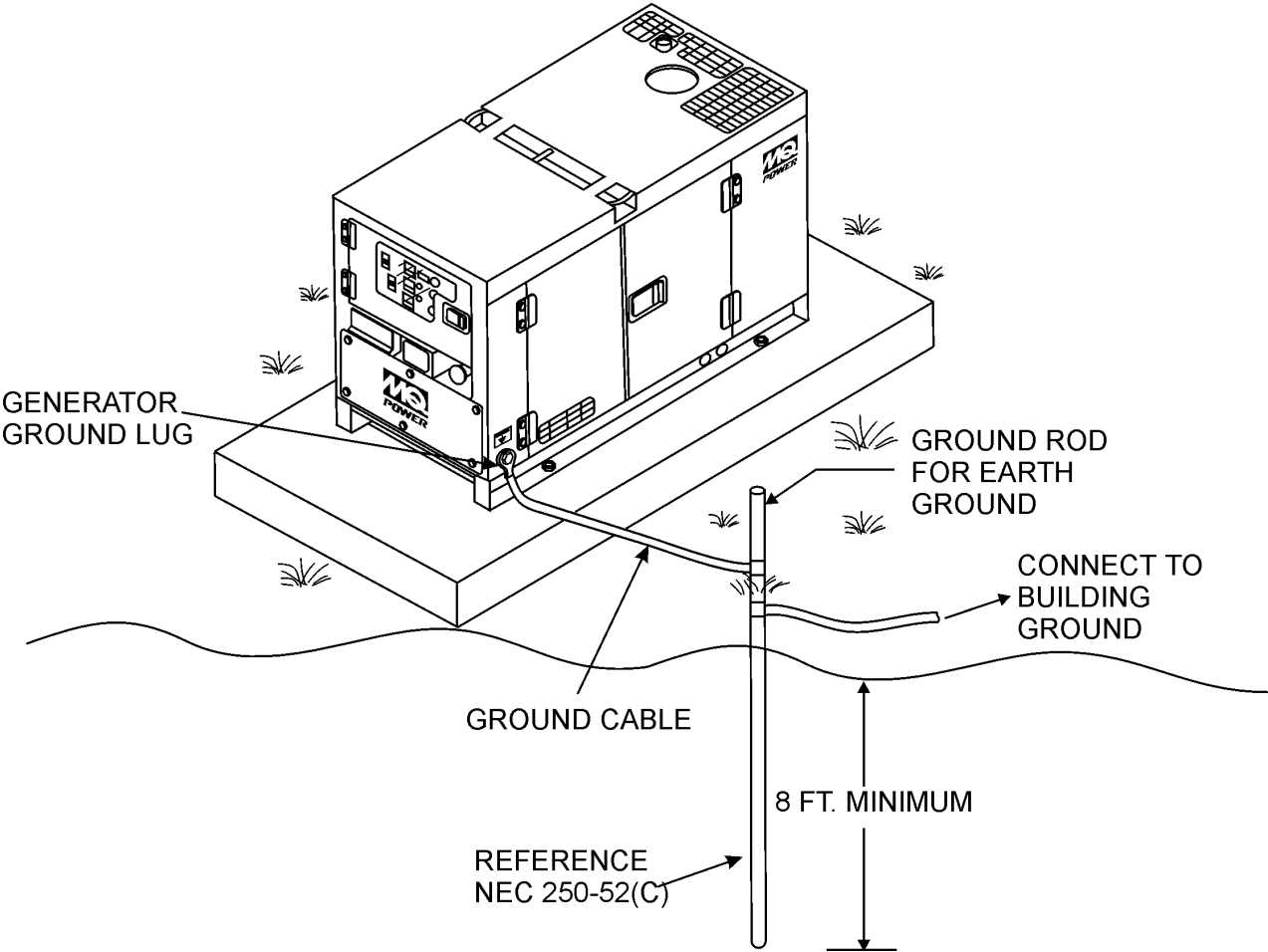

Figure 27. Typical Generator Grounding Application

CAUTION :



Always check Local, State, and Federal Laws before grounding generator.

General Inspection Prior to Operation

The DCA-500SSK generator has been thoroughly inspected and accepted prior to shipment from the factory. However, be sure to check for damaged parts or components, or loose nuts and bolts, which could have occurred in transit.

Extension Cable

When electric power is to be provided to various tools or loads at some distance from the generator, extension cords are normally used. Cables should be sized to allow for distance in length and amperage so that the voltage drop between the generator and point of use (load) is held to a minimum. Use the Cable Selection Guide (Table 8) for selecting proper cable size.

Circuit Breakers

To protect the generator from an overload, a 3-pole, 1400 amp, **main** circuit breaker is provided to protect the UVW output terminals from overload. In addition two single-pole, 20 amp **GFCI** circuit breakers are provided to protect the GFCI receptacles from overload. Three 50 amp **load** circuit breakers have also been provided to protect the load side of the generator from overload. Make sure to switch **ALL** circuit breakers to the "OFF" position prior to starting the engine.

NOTE

ALWAYS consult with a licensed electrician for correct extension cord wire size.

Table 10. Cable Selection (60 Hz, Single Phase Operation)

Current in Amperes	Load In Watts		Maximum Allowable Cable Length			
	At 120 Volts	At 240 Volts	#10 Wire	#12 Wire	#14 Wire	#16 Wire
2.5	300	600	1000 ft.	600 ft.	375 ft.	250 ft.
5	600	1200	500 ft.	300 ft.	200 ft.	125 ft.
7.5	900	1800	350 ft.	200 ft.	125 ft.	100 ft.
10	1200	2400	250 ft.	150 ft.	100 ft.	
15	1800	3600	150 ft.	100 ft.	65 ft.	
20	2400	4800	125 ft.	75 ft.	50 ft.	

CAUTION: Equipment damage can result from low voltage.

Lubrication Oil

Fill the engine crankcase with lubricating oil through the filler hole, but do not overfill. Make sure the generator is level. With the dipstick inserted all the way, but without being screw into the filler hole, verify that the oil level is maintained between the two notches (Figure 28) on the dipstick. See Table 9 for proper selection of engine oil.

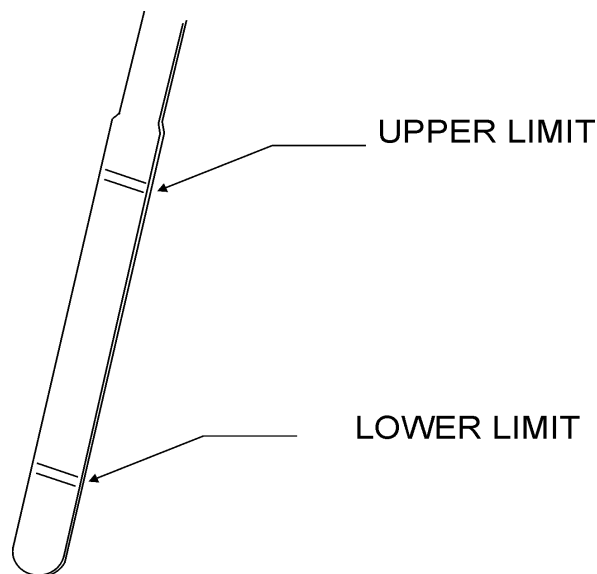

Figure 28. Engine Oil Dipstick

When checking the engine oil, be sure to check if the oil is clean and viscous. If the oil is not clean, drain the oil by removing the oil drain plug, and refill with the specified amount of oil as outlined in the **Komatsu Engine Owner's Manual**.

Fuel

Fill the fuel tank with clean and fresh **diesel fuel**. **DO NOT** fill the tank beyond capacity.

Pay attention to the fuel tank capacity when replenishing fuel. Refer to the fuel tank capacity listed on page 26, Specification Table 7.

The fuel tank cap must be closed tightly after filling. Handle fuel in a safety container. If the container does not have a spout, use a funnel. Wipe up any spilled fuel immediately.

CAUTION :



Never fill the fuel tank while the engine is running or in the dark. Diesel spillage on a hot engine can cause a fire or explosion. If diesel spillage occurs, wipe up the spilled diesel completely to prevent fire hazards.

Coolant

Use only drinkable tap water. If hard water or water with many impurities is used, the inside of the engine and radiator may become coated with deposits and cooling efficiency will be reduced.

An anticorrosion additive added to the water will help prevent deposits and corrosion in the cooling system. See the engine manual for further details.

Table 11. Recommended Motor Oil

Temperature Range	Type Oil
104° F ~ 23° F (40° C ~ -5°C)	SAE 30
23° F ~ 5° F (-5° C ~ -15°C)	SAE 20 or SAE 10W-30
Below 5° C (-15°)	SAE 10W or SAE 10W-30

CAUTION :



When adding coolant or antifreeze to the radiator, do not remove the radiator cap until the unit has completely cooled.

Day-to-day addition of coolant is done from the reserve tank. When adding coolant to the radiator, **DO NOT** remove the radiator cap until the unit has completely cooled. See Table 12 for engine, radiator, and reserve tank coolant capacities. Make sure the coolant level in the reserve tank is always between the "H" and the "L" markings.

Table 12. Coolant Capacity

Engine and Radiator	31.4Gal. (119.0 Liters)
Reserve Tank	2 Quarts (1.9 Liters)

Operation in Freezing Weather

When operating in freezing weather, be certain the proper amount of antifreeze (Table 13) has been added.

Table 13. Anti-Freeze Operating Temperatures

Vol % Anti-Freeze	Freezing Point		Boiling Point	
	°C	°F	°C	°F
40	-24	-12	106	222
50	-37	-34	108	226

NOTE

When the antifreeze is mixed with water, the antifreeze mixing ratio must be less than 50%.

Cleaning the Radiator

The engine may overheat if the radiator fins become overloaded with dust or debris. Periodically clean the radiator fins with compressed air. Cleaning inside the machine is dangerous, so clean only with the engine turned off and the battery disconnected.

Air Cleaner

Periodic cleaning/replacement is necessary. See maintenance section for instruction to cleaning/replacing air cleaner.

Fan Belt Tension

A slack fan belt may contribute to overheating, or to insufficient charging of the battery. Inspect the fan belt for damage and wear. See maintenance section on replacing belts. To adjust tension:

1. Insert a bar between alternator and the cylinder block to fix alternator in position. When fixing the alternator in position, insert a wooden block between the bar and alternator to prevent damage to the alternator.
2. Loosen bolts and nuts located on the alternator.
3. Move alternator with the bar so the deflection of the belt is approx. 8mm.
4. Tighten the bolt and nuts to fix the alternator back to position.

The fan belt tension is proper if the fan belt bends 7 to 10 mm (Figure 29) when depressed with the thumb as shown below.

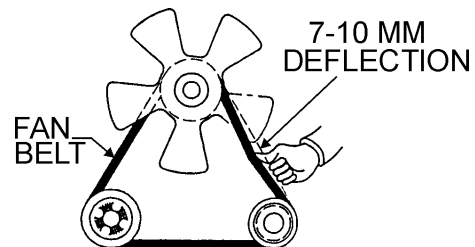

Figure 29. Fan Belt Tension

CAUTION :



Never place hands near the belts or fan while the generator set is running.

Battery Cable Installation

ALWAYS be sure the battery cables (Figure 30) are properly connected to the battery terminals as shown below. The **RED** cable is connected to the positive terminal of the battery, and the **BLACK** cable is connected to the negative terminal of the battery.

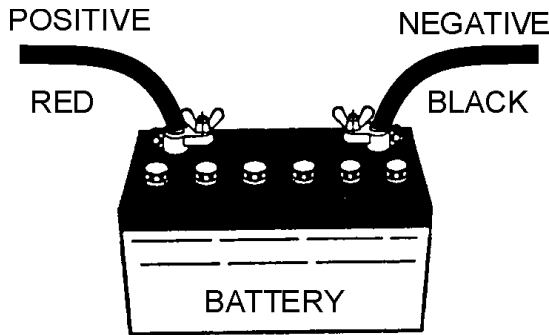

Figure 30. Battery Connections

CAUTION :



If the battery cable is connected incorrectly, electrical damage to the generator will occur. Pay close attention to the polarity of the battery when connecting the battery.

When connecting battery do the following:

1. **DO NOT** connect the battery cables to the battery terminals when the **Off/Manual/Auto** switch is in either the manual or auto position (ON). **ALWAYS** make sure that the Off/Manual/Auto switch is in the OFF position when connecting the battery.
2. Place a small amount of grease around both battery terminals. This will ensure a good connection and will help prevent corrosion around the battery terminals.

CAUTION :

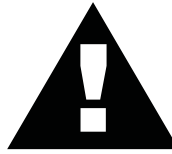

Inadequate battery connections may cause poor starting of the generator, and create other malfunctions.

Wiring

Inspect the entire generator for bad or worn electrical wiring or connections. If any wiring or connections are exposed (insulation missing) replace wiring immediately.

Piping and Hose Connection

Inspect all piping, oil hose, and fuel hose connections for wear and tightness. Tighten all hose clamps and check hoses for leaks.

If any hose (fuel or oil) lines are defective replace them immediately.

Battery

This unit is of negative ground **DO NOT** connect in reverse. Always maintain battery fluid level between the specified marks. Battery life will be shortened, if the fluid level is not properly maintained. Add only distilled water when replenishment is necessary.

The battery is sufficiently charged if the specific gravity of the battery fluid is 1.28 (at 68°F). If the specific gravity should fall to 1.245 or lower, it indicates the battery is discharged and needs to be recharged or replaced.

Check to see whether the battery cables are loose. Poor contact may result in poor starting or malfunctions. Always keep the terminals firmly tightened. Coating the terminals with a thin film of grease will help inhibit corrosion.

Single Phase Load

Always be sure to check the nameplate on the generator and equipment to insure the wattage, amperage and frequency requirements are satisfactorily supplied by the generator for operating the equipment.

Generally, the wattage listed on the nameplate of the equipment is its rated output. Equipment may require 130—150% more wattage than the rating on the nameplate, as the wattage is influenced by the efficiency, power factor and starting system of the equipment.

NOTE

If wattage is not given on the equipment's name plate, approximate wattage may be determined by multiplying nameplate voltage by the nameplate amperage.

$$\text{WATTS} = \text{VOLTAGE} \times \text{AMPERAGE}$$

The power factor of this generator is 0.8. See Table 14. below when connecting loads.

Table 14. Power Factor By Load

Type Of Load	Power Factor
Single-phase induction motors	0.4 - 0.75
Electric heaters, incandescent lamps	1.0
Fluorescent lamps, mercury lamps	0.4 - 0.9
Electronic devices, communication equipment	1.0

Three Phase Load

When calculating the power requirements for 3-phase power use the following equation:

$$\text{KVA} = \frac{\text{VOLTAGE} \times \text{AMPERAGE} \times 1.732}{1000}$$

CAUTION:



Motors and motor-driven equipment draw much greater current for starting than during operation.

An inadequate size connecting cable which cannot carry the required load can cause a voltage drop which can burn out the appliance or tool and overheat the cable.

- When connecting a resistance load such as an incandescent lamp or electric heater, a capacity of up to the generating set's rated output (kW) can be used.
- When connecting a fluorescent or mercury lamp, a capacity of up to the generating set's rated output (kW) multiplied by 0.6 can be used.
- When connecting an electric drill or other power tools, pay close attention to the required starting current capacity.

CAUTION:



When connecting ordinary power tools, a capacity of up to the generating set's rated output (kW) multiplied by 0.8 can be used.

Before connecting this generator to any building's electrical system, a licensed electrician must install an isolation (transfer) switch. Serious injury or death may result without this transfer switch.

NOTE

If output (kVA) is not given on the equipment nameplate, approximate output may be determined by multiplying voltage by amperage by $\sqrt{3}$.

DCA-500SSK — GENERATOR START-UP PROCEDURE (MANUAL)

WARNING:



The engine's exhaust contains harmful emissions. **ALWAYS** ventilate the exhaust when operating inside tunnels, excavations or buildings. Direct exhaust away from nearby personnel.

Before Starting Engine

1. Check the lubricating oil level prior to starting the engine. Make sure the generator is level. The oil level must be maintained between two notches on the dipstick.
2. When there is not enough lubricating oil, fill the crankcase with high grade motor oil. Use a high quality detergent oil classified CC or higher (See Table 9 on page 41).
3. Check the coolant level in the radiator and subtank. Replenish with antifreeze as necessary. Always maintain the coolant level between the **FULL** and **LOW** markings on the coolant container. Be sure the radiator cap is fastened securely.
4. Check the fuel level on the fuel gauge. If fuel is low, fill the fuel tank with clean fresh diesel fuel. If diesel spillage occurs, completely wipe up the spilled fuel immediately.

Before Starting Generator and Control Panel

CAUTION:



NEVER start the engine with the **main, GFCI** or **load** circuit breakers in the **ON** position.

1. Be sure to disconnect the electrical load and switch the **MAIN LOAD** and **G.F.C.I.** circuit breakers (Figure 31) to the "OFF" position prior to starting the engine.

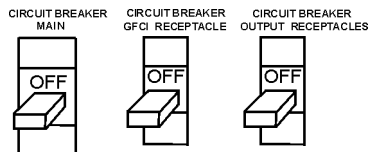

Figure 31. Main, GFCI and Load Circuit Breakers

2. Connect the load to the UVW terminals as shown in Figure 32. These terminals can be found on the output terminal panel, see page 37, Figure 14. To gain access to the output terminals lift the UVW cover. Tighten the terminal nuts securely to prevent load wires from slipping out.

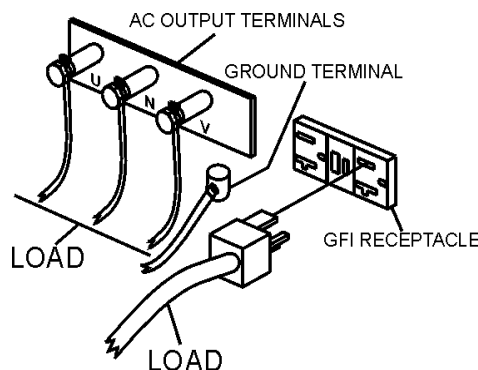

Figure 32. UVW Terminal Lugs (Load)

3. Connect the negative battery cable (BLACK) to the negative post on the battery (Figure 33).

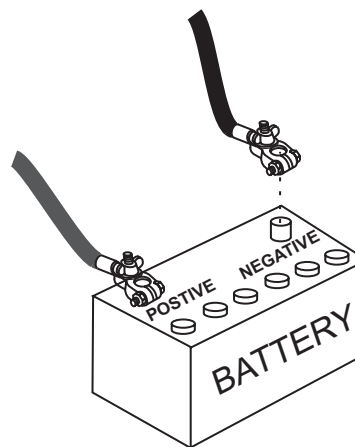

Figure 33. Battery Connections

DCA-500SSK — GENERATOR START-UP PROCEDURE (MANUAL)

4. Close all engine enclosure doors (Figure 34).

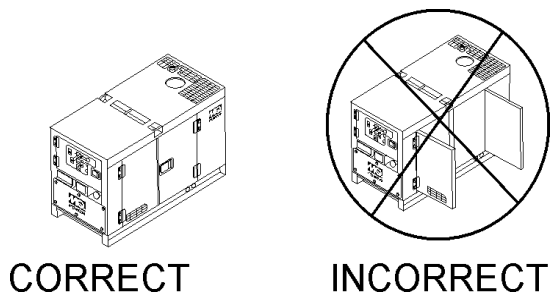

Figure 34. Engine Enclosure Doors

7. Place the Off/Manual/Auto switch (Figure 38) in the **MANUAL** position (down). Observe that the engine begins to crank.

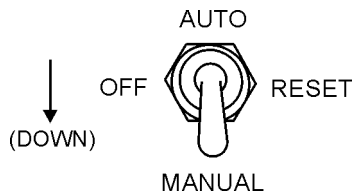

Figure 38. Off/Manual/Auto Switch (Manual)

5. Set the battery ON/OFF switch (Figure 35) to the ON position.

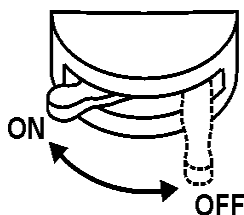

Figure 35. Battery ON/OFF Switch

8. After engine starts, verify that the "Engine Running" status LED (Figure 39) on the Microprocessor Engine Control Module (MPEC) display is "ON" (lit).

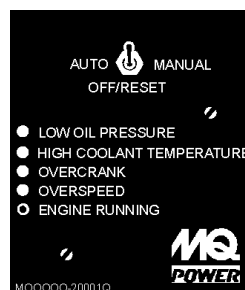

Figure 39. MPEC Engine Running Status LED

6. When starting the generator in **COLD** weather conditions, press and hold the engine preheat button (Figure 36) until the preheat lamp (Figure 37) is lit (ON).



Figure 36. Engine Pre-Heat Button

9. The generator's frequency meter (Figure 40) displays the 60 cycle output frequency in **HERTZ**.



Figure 37. Engine Pre-Heat Lamp

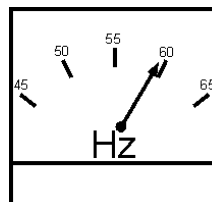

Figure 40. Frequency Meter (Hz)

DCA-500SSK — GENERATOR START-UP PROCEDURE (MANUAL)

10. The generator's voltage meter (Figure 41) displays the 120 VAC in **VOLTS**. If the voltage is not within the specified frequency tolerance, use the voltage adjustment control knob (Figure 42) to increase or decrease the desired voltage.

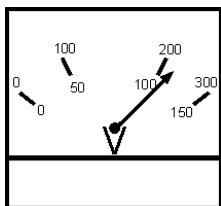

Figure 41. Voltage Meter (Volts)

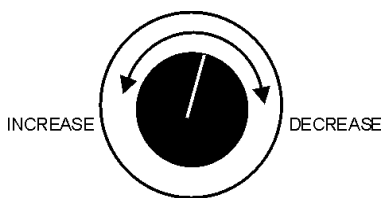

Figure 42. Voltage Adjust Control Knob

11. The ammeter (Figure 43) will indicate zero amps with no load applied. When a load is applied, this meter will indicate the amount of current that the load is drawing from the generator's alternator.

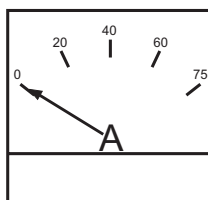

Figure 43. Ammeter (No Load)

12. The engine oil pressure gauge (Figure 44) will indicate the oil pressure (kg/ cm²) of the engine. Under normal operating conditions the oil pressure should be approximately 25 psi.

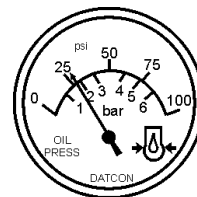

Figure 44. Oil Pressure Gauge

13. The coolant temperature gauge (Figure 45) will indicate the coolant temperature. Under normal operating conditions the coolant temperature should be between 165 and 215 degrees Fahrenheit (Green Zone).

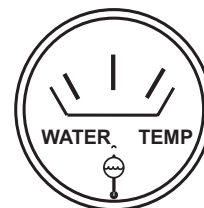

Figure 45. Coolant Temperature Gauge

DCA-500SSK — GENERATOR START-UP PROCEDURE (MANUAL)

14. Set the engine speed switch (Figure 46) to low to idle engine, set to high when a load is being applied.

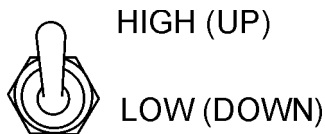

Figure 46. Engine Speed Switch

15. The tachometer (Figure 47) will indicate the speed of the engine when the generator is operating. Under normal operating conditions this speed should be approximately 1800 RPM's.

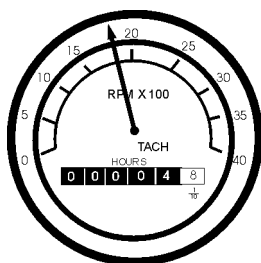

Figure 47. Engine Tachometer

16. Turn the MAIN, GFCI and LOAD circuit breakers to their ON position (Figure 48).

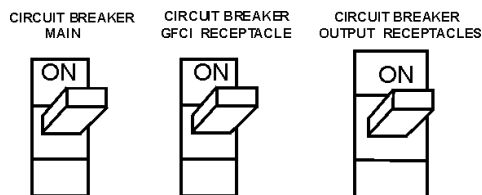

Figure 48. Main and GFCI Circuit Breakers

17. Observe the generator's ammeter (Figure 49) and verify that it reads the anticipated amount of current with respect to the load. Remember the ammeter will only display a current reading if the load is in use.

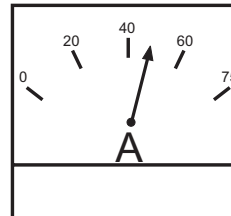

Figure 49. Ammeter (Load)

18. The generator will run until manually stopped or an abnormal condition occurs.

DCA-500SSK — GENERATOR START-UP PROCEDURE (AUTO)

When starting generator in Auto mode use the "Manual Start-up" procedure except where noted (see below).

1. Perform steps 1 through 6 (Before Starting, page 49-50) as outlined in the manual starting procedure.
2. Place the Off/Manual/Auto switch (Figure 50) in the **AUTO** position (up). Observe that the engine begins to crank.

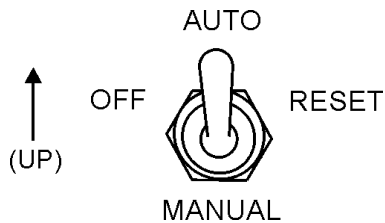
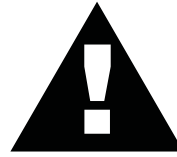

Figure 50. Off/Manual Auto Switch (AUTO)

3. Continue to follow the steps outline in the manual start-up procedure (start at step 9, page 50).

CAUTION:



When running the generator in the **AUTO** mode, remember the generator can start up at any time without warning. **NEVER** attempt to perform any maintenance when the generator is in the auto mode.

CAUTION:



Before connecting this generator to any building's electrical system, a **licensed electrician** must install an isolation (transfer) switch. Serious ***injury*** or ***death*** may result without this transfer switch.

DCA-500SSK — GENERATOR SHUTDOWN PROCEDURE

Engine Shutdown

To shutdown the generator use the following procedure:

1. Place both the **MAIN**, **GFCI** and **LOAD** circuit breakers to the "OFF position"
2. Set the engine speed switch (Figure 51) to the idle (low) position (If optional part installed).

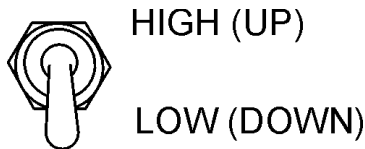

Figure 51. Engine Speed Switch

3. Let the engine cool by running it for 3-5 minutes with no load applied.
4. Place the Off/Manual/Auto Switch (Figure 52) in the "**OFF/RESET**" position

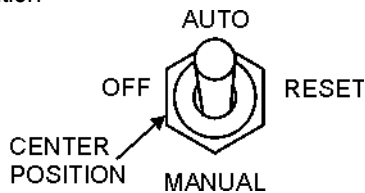

Figure 52. Off/Manual Auto Switch (OFF)

5. Verify that the "Engine Running" status LED (Figure 53) on the Microprocessor Engine Control Module (MPEC) display is "OFF" (not lit).

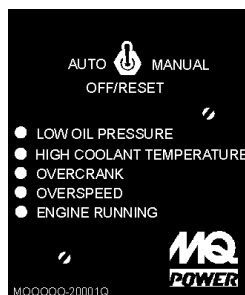

Figure 53. MPEC Engine Running Status LED (OFF)

6. Remove the load from the UVW terminal strip (Figure 32 page 49).

Emergency Stop

To stop the engine in the event of an emergency, **PUSH** the emergency stop button (Figure 54) inward. This button is located on the generator's control panel, see page 34, Figure 10.

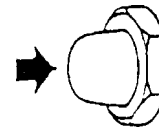

Figure 54. Emergency Stop Button

CAUTION:



NEVER stop the engine suddenly except in an emergency. **DO NOT** use the emergency stop switch as a method of shutting down the engine. This switch is **ONLY** to be used in the event of an emergency.

General Inspection

Prior to each use, the generating set should be cleaned and inspected for deficiencies. Check for loose, missing or damaged nuts, bolts or other fasteners. Also check for fuel or oil leaks.

Air Cleaner

Every 50 hours: If dust indicator is red, clean the air cleaner element.

Outer Element:

1. Loosen wing bolt, remove dust cup, then remove wing nut and take out element.
2. Clean the inside of the body and cover using a damp cloth.
3. Blow dry with compressed air (0.69Mpa [7kgf.cm², 99.4 PSI] maximum) against the side of the element along the pleats. Then blow dry against outside along the pleats, then against inside again.
4. Remove one seal each time the element is cleaned.
5. Replace the outer element after cleaning it 6 times or after one year. Replace the outer element if indicator is red even after cleaning it.
6. Check the inner cylinder element clamping nut for looseness, and retighten if necessary.
7. If seal washer is damaged or the threads of wing nut are damaged, replace.
8. Remove evacuator valve and clean it with compressed air. Reinstall.

Inner element (if equipped)

1. Remove the cover and outer element, then remove the inner element.
2. Cover the air connector opening (outer side) with clean cloth or cloth tape.
3. Clean the inside of the body. Remove air connector opening protection.
4. Install a new inner cylinder element to the cylinder and tighten the nut.
5. Install element.
6. After replacing the element, press the button of the dust indicator to return the red piston to its original position.

Fuel Addition

Add diesel fuel (the grade may vary according to season and locations). Always pour through the mesh filter.

Removing Water from the Tank

After prolonged use, water and other impurities accumulate in the bottom of the tank. Occasionally remove the drain cock and drain the contents. During cold weather, the greater the empty volume inside the tank, the easier it is for water to condense. This can be reduced by always keeping the tank as full as possible.

Air Removal

If air enters the fuel injection system of a diesel engine, starting becomes impossible. After running out of fuel, or after disassembling the fuel system, bleed the system according to the following procedure.

To restart after running out of fuel, turn the key switch to the "START" position for 15-30 seconds. Try again, if needed. This unit is equipped with an automatic air bleeding system.

Service Daily

If engine is operating in very dusty and dry grass conditions, a clogged air cleaner will result in high fuel consumption, loss of power and excessive carbon buildup in the combustion chamber.

Cleaning the Fuel Strainer

Clean the fuel strainer if it contains dust or water. Remove dust or water in the strainer cap and wash it in diesel. Securely fasten the fuel strainer cap so that fuel will not leak. Check the fuel strainer every 200 hours of operation or once a month.

Check Oil Level

Check the crankcase oil level prior to each use, or when the fuel tank is filled. Insufficient oil may cause severe damage to the engine. Make sure the generator is level. The oil level must be between the two notches on the dipstick as shown in Figure 14, page 39.

Flushing Out Radiator and Changing Coolant

1. Stop the engine and allow to cool. Tighten valve of the corrosion resistor (if equipped).
2. Turn water filler cap slowly and remove it.
3. Prepare a container to catch the coolant, then open drain plug of the radiator or heat exchanger and drain plug of the engine, and drain the coolant.
4. After draining the coolant, close drain plugs and fill with tap water.

5. When the water level is near the mouth of the water filler, open drain plugs and start the engine, and run at low idling. Keep the engine running at low idling and flush the radiator for about 10 minutes.
6. Adjust the flow of the water flowing in and draining out to ensure that the radiator is always full during the flushing operation. While flushing water through the system, watch carefully the water inlet hose does not come out of the radiator filler port.
7. After flushing, stop the engine, open drain plug and drain the water, then close drain plugs.
8. After draining the water, flush the system with a flushing agent. See instructions on flushing agent label.
9. After flushing, open drain plugs and drain out all the water, then close drain plugs and add tap water so the water level is near the mouth of the water filler.
10. When the water level is near the mouth of the water filler, open drain plugs and start the engine, run at low idling and continue to flush the system until clean water comes out. Adjust the flow of the water flowing in and draining out to ensure the radiator is always full during the flushing operation.
11. When clean water comes out, stop the engine, drain all the water, then close drain plugs.
12. Remove the corrosion resistor (if equipped) and open valve.
13. Supply water until it flows over the water filler.
14. Drain the water inside reserve tank, clean the inside of the reserve tank, then fill with coolant/water mixture to between the full and low lines.
15. Stop the engine, wait for 3 minutes, add tap water until the water level reaches near the water filler port, then tighten the radiator cap.

Check Electric Heater (If equipped)

Before starting in cold weather (once a year), please contact your Komatsu distributor for inspection. Remove electric heater from the engine intake manifold and check for disconnections or dirt. When checking or installing the electric heater, replace the gasket with a new part.

Changing Oil

1. Make sure the oil is cool before changing.
2. Set a container directly under the drain plug of the oil pan. Loosen the drain plug slowly.
3. Check the drained oil for excessive metal particles or foreign material. Contact the distributor if there is metal particles or foreign material.
4. Using a filter wrench, turn filter cartridge to the left to remove it. If the filter cartridge is filled with a large amount of oil, wait 10 minutes or so before removing. Make sure there is no old gasket stuck on the filter holder.
5. Tighten drain plug. Clean the filter holder, fill the new filter cartridge with clean engine oil, coat the packing and thread of the new filter cartridge with engine oil, then install it to the filter holder. Tighten until the gasket surface contacts the seal surface of the filter holder, then tighten it a further 3/4 to 1 turn.
6. Add engine oil through oil filler until the oil level is between the H and L marks on the dipstick.
7. Run the engine at idling for a short time, then stop the engine. Recheck the oil level and fill as necessary.

Replacing fuel filter

1. Set the container under the filter cartridge to catch fuel.
2. Using a filter wrench, turn the filter cartridge to the left to remove it.
3. Clean the filter holder, fill the new filter cartridge with fuel, coat the packing surface of the filter cartridge with engine oil, then install the cartridge to the filter holder.
4. When installing, tighten until the packing surface contacts the seal surface of the filter holder then tighten a further 2/3 of a turn. If the filter cartridge is tighten too much, the packing will be damaged and will cause fuel leakage. Fuel leakage will occur if the filter cartridge is not tightened enough. Always tighten to the correct angle.
5. After replacing filter cartridge, loosen air bleed plug.
6. Loosen the knob of feed pump, and pump it up and down until no bubbles come out with the fuel from air bleed plug.

7. After bleeding the air, tighten air bleed plug, then push in the knob of feed pump and lock it in position.
8. Replace Corrosion resistor cartridge (if equipped)
9. Screw in valves at the top of the corrosion resistor.
10. Using a filter wrench, turn the cartridge to the left to remove it.
11. Coat the seal surface of the new cartridge with engine oil and install it to the filter holder.
12. Tighten until the packing surface contacts the seal surface of the filter holder, then tighten a further 2/3 of a turn.
13. Open valves.

Cleaning breather element

1. Loosen the clamp, then remove the hose and take out breather. Wipe off the dirt around the breather. Check the O-ring, and replace if necessary.
2. Wash the breather in diesel fuel or flushing oil, blow dry with compressed air, then reinstall it.
3. Inspect the hose and if there is any deteriorated oil stuck inside the hose. Replace hose if necessary.

Greasing

Using a grease pump, grease the fan hub (1 place) and tension pulley (2 places).

Generator Storage

For storage of the generator for over 30 days, the following is required:

- Fill the fuel tank completely, lubricate and change oil.
- Disconnect the negative terminals of the battery and cover it, or remove it from the machine and store it separately.
- If the ambient temperature is expected to drop below 0°C, add antifreeze to the radiator.

Removal from long term storage:

- Apply oil to the engine valve and rocker arms, and examine the operating condition of the valves.
- Remove the oil filler pipe from the turbocharger oil inlet port, add 0.5-1L (0.13-0.26gal) of oil to the turbocharger, reinstall the oil filler pipe.
- Change the oil in engine oil pan.
- Replace all the filters.
- Flush the inside of the cooling system.
- Drain the water from the fuel tank and bleed the air from the fuel system.
- If the engine has not been started for more than one year, contact your Komatsu distributor to have engine overhauled.

TABLE 15.

INSPECTION / MAINTENANCE		10 Hrs DAILY	250 Hrs	500 Hrs	1000 Hrs
ENGINE	Check Engine Fluid Levels	X			
	Check Air Cleaner	X			
	Check Battery Acid Level	X			
	Check Fan Belt Condition	X			
	Check for Leaks	X			
	Check for Loosening of Parts	X			
	Replace Engine Oil and Filter * ¹		X		
	Clean Air Filter		X		
	Drain Bottom of Fuel Tank		X		
	Clean Unit, Inside and Outside		X		
	Change Fuel Filter * ²			X	
	Clean Radiator and Check Coolant Protection Level			X	
	Replace Air Filter Element				X
	Change Corrosion Resistor				X
	Check all Hoses and Clamps				X
Clean Inside of Fuel Tank				X	
GENERATOR	Measure Insulation Resistance Over 3M ohms		X		

*¹ Replace engine oil and filter at 100 hours, first time only.

*² Replace fuel filter at 250 Hours, first time only.

DCA-500SSK—GENERATOR WIRING DIAGRAM

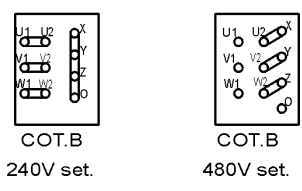
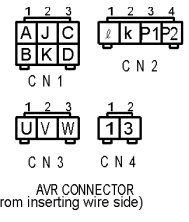
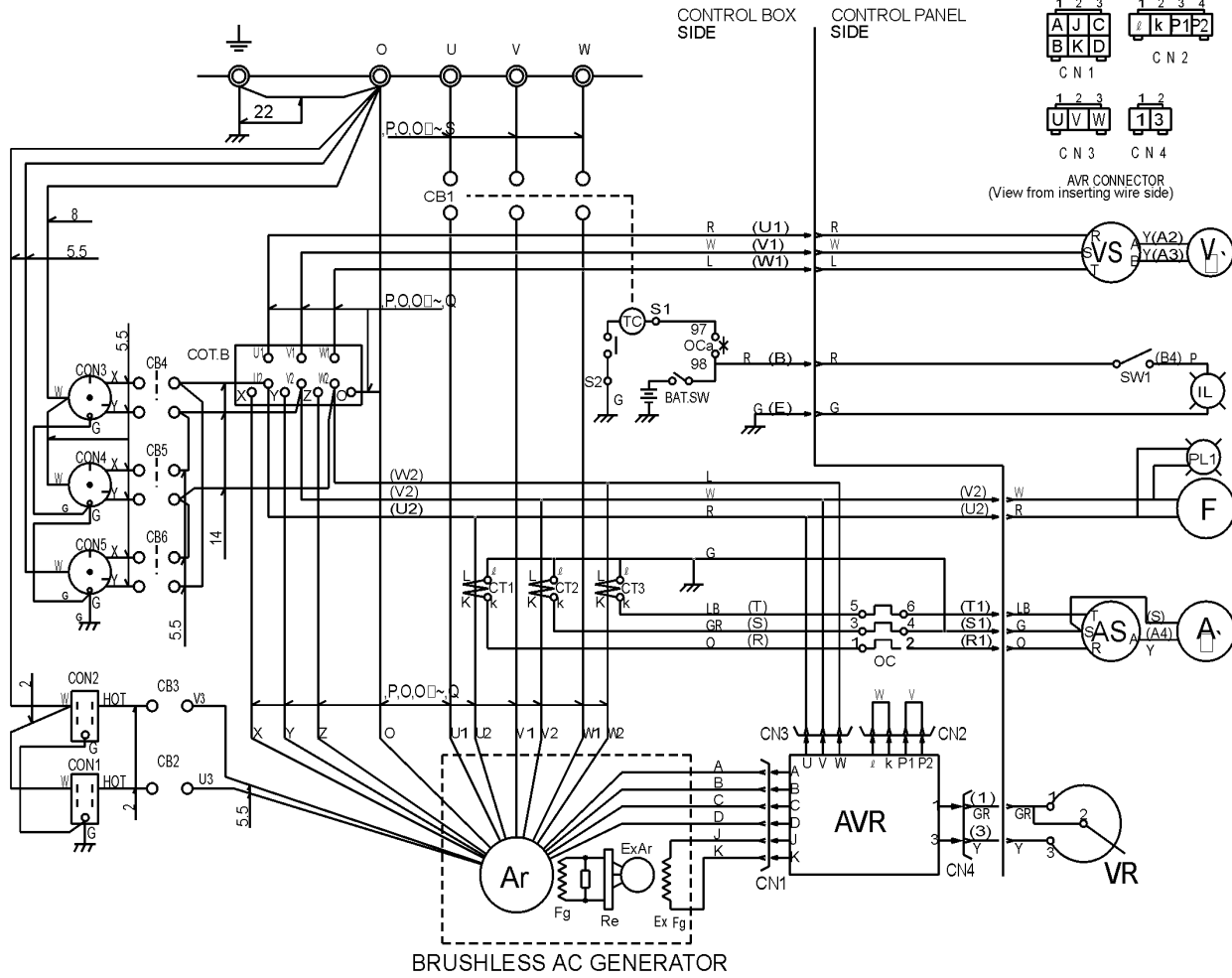

NO MARK WIRE SIZE : 1.25mm²

WIRE SIZE	COLOR CODE	
	WIRE COLOR	WIRE COLOR
125: 125mm ²		
100: 100mm ²	B BRACK	R RED
80: 80mm ²	L BLUE	W WHITE
22: 22mm ²	BR BROWN	Y YELLOW
14: 14mm ²	G GREEN	LB LIGHT BLUE
8 : 8mm ²	GR GRAY	LG LIGHT GREEN
5.5: 5.5mm ²	V VIOLET	O ORANGE
2 : 2mm ²	P PINK	

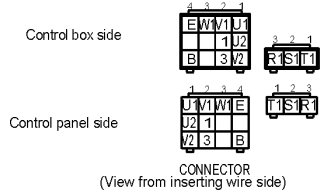

MARK	N A M E
Ar	MAIN GENERATOR ARMATURE WINDING
Fg	MAIN GENERATOR FIELD WINDING
ExAr	EXCITER ARMATURE WINDING
ExFg	EXCITER FIELD WINDING
AVR	AUTOMATIC VOLTAGE REGULATOR
VR	VOLTAGE REGULATING RHEOSTAT
Re	RECTIFIER
b s P I R	CURRENT TRANSFORMER 1000/5A
CB1	CIRCUIT BREAKER 1400A
OC	OVER CURRENT RELAY
COT.B	VOLTAGE CHANGE-OVER BOARD
AS	AMMETER CHANGE-OVER SWITCH
A	AC AMMETER 0 1000,2000A
VS	VOLTMETER CHANGE-OVER SWITCH
V	AC.VOLTMETER 0 600V
F	FREQUENCY METER 45 65Hz
PL1	PILOT LAMP
CB2,3	AUX.CIRCUIT BREAKER 20A
b a s I I	AUX.CIRCUIT BREAKER 50A
CON1,2	AUX.POWER RECEPTACLE 20A
b a m R O	AUX.POWER RECEPTACLE 50A
IL	PANEL LIGHT
SW1	PANEL LIGHT SWITCH

DCA-500SSK—ENGINE WIRING DIAGRAM

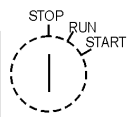
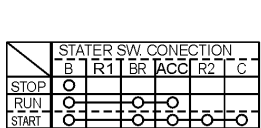
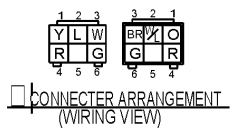
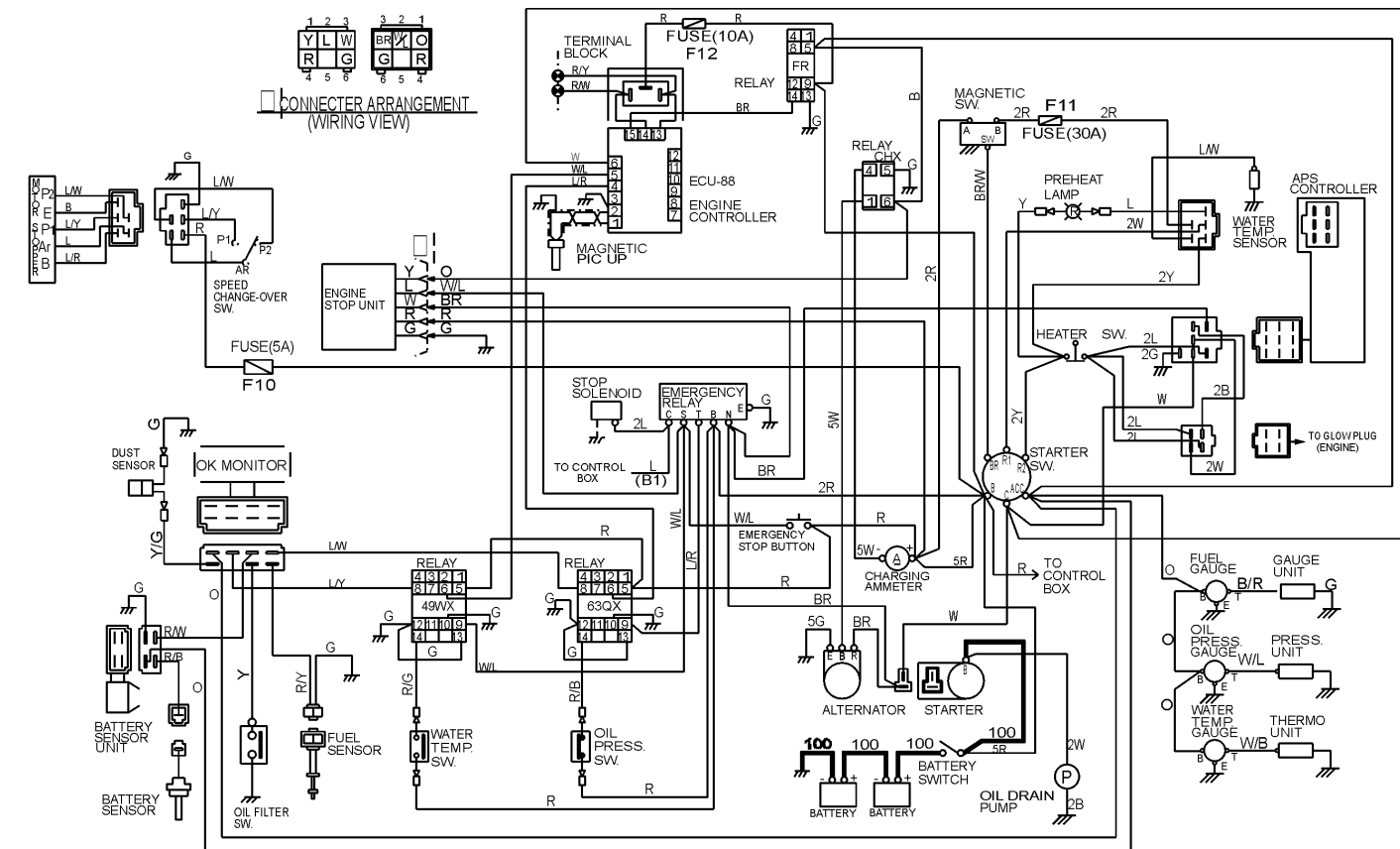

WIRE SIZE	COLOR CODE	WIRE COLOR	WIRE COLOR
100 : 100mm ²	B	BRACK	R
38 : 38mm ²	L	BLUE	W
22 : 22mm ²	BR	BROWN	Y
14 : 14mm ²	G	GREEN	LB
5 : 5mm ²	GR	GRAY	LG
2 : 2mm ²	V	VIOLET	O
NO MARK:1.25mm ²	P	PINK	

DCA-500SSK —TROUBLESHOOTING (ENGINE)

All breakdowns can be prevented by proper handling and maintenance inspections, but in the event of a breakdown, please take a remedial action following the diagnosis based

on the Engine Troubleshooting (Table 16) information shown below and on the proceeding page. If the problem cannot be remedied, consult our company's business office or service plant.

TABLE 16. ENGINE TROUBLESHOOTING

SYMPTOM	POSSIBLE PROBLEM	SOLUTION
Engine does not start.	No fuel?	Replenish fuel.
	Air in the fuel system?	Bleed system.
	Water in the fuel system?	Remove water from fuel tank.
	Fuel pipe clogged?	Clean fuel pipe.
	Fuel filter clogged?	Clean or change fuel filter.
	Excessively high viscosity of fuel or engine oil at low temperature?	Use the specified fuel or engine oil.
	Fuel with low cetane number?	Use the specified fuel.
	Fuel leak due to loose injection pipe retaining nut?	Tighten nut.
	Incorrect injection timing?	Adjust.
	Fuel cam shaft worn?	Replace.
	Injection nozzle clogged?	Clean injection nozzle.
	Injection pump malfunctioning?	Repair or replace.
	Seizure of crankshaft, camshaft, piston, cylinder liner or bearing?	Repair or replace.
	Compression leak from cylinder?	Replace head gasket, tighten cylinder head bolt, glow plug and nozzle holder.
	Improper valve timing?	Correct or replace timing gear.
Piston ring and liner worn?	Replace.	
Excessive valve clearance?	Adjust.	
Starter does not run.	Battery discharged?	Charge battery.
	Starter malfunctioning?	Repair or replace.
	Key switch malfunctioning?	Repair or replace.
	Wiring disconnected?	Connect wiring.

DCA-500SSK — TROUBLESHOOTING (ENGINE)

TABLE 16. ENGINE TROUBLESHOOTING (CONTINUED)

SYMPTOM	POSSIBLE PROBLEM	SOLUTION
Engine revolution is not smooth.	Fuel filter clogged or dirty?	Clean or change.
	Air cleaner clogged?	Clean or change.
	Fuel leak due to loose injection pipe retaining nut?	Tighten nut.
	Injection pump malfunctioning?	Repair or replace.
	Incorrect nozzle opening pressure?	Adjust.
	Injection nozzle stuck or clogged?	Repair or replace.
	Fuel over flow pipe clogged?	Clean.
	Governor malfunctioning?	Repair.
Either white or blue exhaust gas is observed.	Excessive engine oil?	Reduce to the specified level.
	Piston ring and liner worn or stuck?	Repair or replace.
	Incorrect injection timing?	Adjust.
	Deficient compression?	Adjust top clearance.
Either black or dark gray exhaust gas is observed.	Overload?	Lessen the load.
	Low grade fuel used?	Use the specified fuel.
	Fuel filter clogged?	Clean or change.
	Air cleaner clogged?	Clean or change.
	Deficient nozzle injection?	Repair or replace the nozzle.
Deficient output.	Incorrect injection timing?	Adjust.
	Engine's moving parts seem to be seizing?	Repair or replace.
	Uneven fuel injection?	Repair or replace the injection pump.
	Deficient nozzle injection?	Repair or replace the nozzle.
	Compression leak?	Replace head gasket, tighten cylinder head bolt, glow plug and nozzle holder.

DCA-500SSK —TROUBLESHOOTING (GENERATOR/ENGINE)

All breakdowns can be prevented by proper handling and maintenance inspections, but in the event of a breakdown, please take a remedial action following the diagnosis based

on the Engine and Generator Troubleshooting (Table 17) information shown below. If the problem cannot be remedied, consult our company's business office or service plant.

TABLE 17. GENERATOR TROUBLESHOOTING

SYMPTOM	POSSIBLE PROBLEM	SOLUTION
No Voltage Output	AC Voltmeter defective?	Check output voltage using a voltmeter.
	Is wiring connection loose?	Check wiring and repair.
	Is AVR defective?	Replace if necessary.
	Defective Rotating Rectifier?	Check and replace.
Low Voltage Output	Is engine speed correct?	Turn engine throttle lever to "High".
	Is wiring connections loose?	Check wiring and repair.
	Defective AVR?	Replace if necessary.
High Voltage Output	Is wiring connections loose?	Check wiring and repair.
	Defective AVR?	Replace if necessary.
Circuit Breaker Tripped	Short Circuit in load?	Check load and repair.
	Over current?	Confirm load requirements and reduce.
	Defective circuit breaker?	Check and replace.
	Over current Relay actuated?	Confirm load requirement and replace.

DCA-500SSK — TROUBLESHOOTING (MPEC)

All breakdowns can be prevented by proper handling and maintenance inspections, but in the event of a breakdown, please take a remedial action following the diagnosis based

on the MPEC Troubleshooting (Table 18) information shown below. If the problem cannot be remedied, consult our company's business office or service plant.

TABLE 18. MPEC TROUBLESHOOTING

Sympton	Possible Cause	Solution
Low oil pressure light is on.	Low oil level?	Fill oil level.
	Oil pressure sending unit failure?	Replace oil pressure sending unit.
	Time delay malfunction in MPEC?	Refer to dealer.
	Wire shorted?	Inspect/repair wire.
Low coolant level light is on.	Low coolant level?	Fill coolant level.
	Sending unit failure?	Replace sending unit.
	Low battery voltage?	Replace/charge battery.
High coolant temperature light is on.	Fan belt tension incorrect?	Tighten/replace fan belt.
	Air flow is not circulation through radiator?	Clean/repair radiator grill.
	Doors open?	Close doors.
	Exhaust leaking?	Replace/repair gaskets or faulty part.
	Generator being overloaded?	Check/reduce load.
	Thermostat failure?	Replace thermostat.
	Air intake blocked?	Clear all air intakes.
	Temperature switch failure?	Replace temperature switch.
Overcrank light is on.	No or low Fuel?	Fill fuel level.
	MPEC needs to be calibrated?	Refer to dealer.
Overspeed light is on.	RPM engine speed too high?	Adjust RPM.
	Governor actuator needs to be adjusted?	Adjust governor actuator.
	Governor controller needs to be adjusted?	Adjust governor controller.
	MPEC needs to be calibrated?	Refer to dealer.
Loss of MPU light(s) or on.	Magnetic pick up out of adjustment?	Adjust magnetic pick up.
	Magnetic pick up dirty?	Clean magnetic pick up.

EXPLANATION OF CODE IN REMARKS COLUMN

How to read the marks and remarks used in this parts book.

Items Found In the “Remarks” Column

Serial Numbers-Where indicated, this indicates a serial number range (inclusive) where a particular part is used.

Model Number-Where indicated, this shows that the corresponding part is utilized only with this specific model number or model number variant.

Items Found In the “Items Number” Column

All parts with same symbol in the number column, *, #, +, %, or ■, belong to the same assembly or kit.

Note: If more than one of the same reference number is listed, the last one listed indicates newest (or latest) part available.

DCA-500SSK — SUGGESTED SPARE PARTS

DCA-500SSK w/SA6D170AE-1 KOMATSU ENGINE

1 to 5 Units

Qty.	P/N	Description
206125817032...	AIR FILTER
306003117111...	FUEL FILTER
306002111231...	OIL FILTER
26004111030...	CARTRIDGE, CORROSION RESISTOR
10601804887...	CIRCUIT BREAKER
10601810575...	PILOT LAMP, ENGINE TROUBLE
10601810576...	PILOT LAMP, ENGINE TROUBLE
10412222568...	ENGINE FAN BELT
16008155390...	SWITCH STARTER
3615	KEY SET, STARTER SWITCH (2)
20602122281...	OIL SWITCH
16995621691...	RADIATOR HOSE (UPPER)
16162639650...	RADIATOR HOSE (LOWER)
10605505030...	FUEL CAP
10601820625...	AUTOMATIC VOLTAGE REGULATOR
10601807030...	MAIN CIRCUIT BREAKER
10601805840...	CIRCUIT BREAKER
10601802525...	HANDLE, MAIN CURRENT BREAKER
10601840073...	VOLTAGE REGULATOR (RHEOSTAT)
20601840121...	KNOB, VOLTAGE REGULATOR
10601810072...	PILOT LAMP
20601810261...	BULB PILOT LAMP
123S0311150M	CAP, RADIATOR
10602122203...	UNIT OIL PRESSURE
10602123206...	UNIT, WATER TEMPERATURE
10602121052...	CHARGING AMMETER

NOTE

Part number on this Suggested Spare Parts List may super cede/replace the P/N shown in the text pages of this book.

DCA-500SSK — GENERATOR ASSY.

GENERATOR ASSY.

<u>NO.</u>	<u>PART NO.</u>	<u>PART NAME</u>	<u>QTY.</u>	<u>REMARKS</u>
1	8471000002	ROTOR ASSY.	1	
1-1		FIELD ASSY.	1	
1-2	0601842366	RESISTOR	4	
1-3	8171020004	INSULATOR WASHER	6	
1-4	8171020504	INSULATOR WASHER	6	
1-5	8461070002	FAN	1	
1-6	8461614003	COUPLING RING	1	
1-7	0010312025	HEX. HEAD BOLT	6	
	0042512000	LOCK WASHER	6	
1-8	416310004	COUPLING DISK ASSY.	1	
1-9	8461612004	WASHER, COUPLING HUB	1	
1-10	8461015003	BALANCING PLATE	1	
1-11	0012120055	HEX. HEAD BOLT	12	
1-12	0042620000	LOCK WASHER	12	
1-13	8461026023	SET PLATE, RECTIFIER	1	
1-14	0601823282	RECTIFIER	2	
1-15	0018205020	HEX. SOCKET HEAD COP SCREW	4	
	0040005000	LOCK WASHER	4	
	0041205000	PLAIN WASHER	4	
1-16	0010112020	HEX. HEAD BOLT	6	
	0040012000	LOCK WASHER	6	
1-17	0601000209	BALANCING WEIGHT KIT	1	
1-18	7431014003	BEARING FLANGE	1	
1-19	0070106321	BEARING	1	
1-20	0080000105	SNAP RING	1	
2	0012116060	HEX. HEAD BOLT	6	
	0042516000	LOCK WASHER	6	
3	C4130200003	STRATOR ASSY.	1	
3-1	7431323003	CLAMPER	4	
3-2	3871323123	CLAMPER	4	
3-3	7431323204	CLAMPER	2	
3-7	0016310080	HEX. HEAD BOLT	4	
	0030010000	HEX. NUT	4	
	0040010000	LOCK WASHER	8	
	0041210000	PLAIN WASHER	4	
3-5	0017110020	HEX. HEAD BOLT	8	
4	8461315002	END BRACKET	1	
5	C4137000003	FIELD ASSY. EXCITER	1	
6	0012110075	HEX. HEAD BOLT	6	
	0042610000	LOCK WASHER	6	
7	0845044904	GROMMET	1	
8	0010116045	HEX. HEAD BOLT	8	
	0040016000	LOCK WASHER	8	

DCA-500SSK — GENERATOR ASSY.

GENERATOR ASSY.

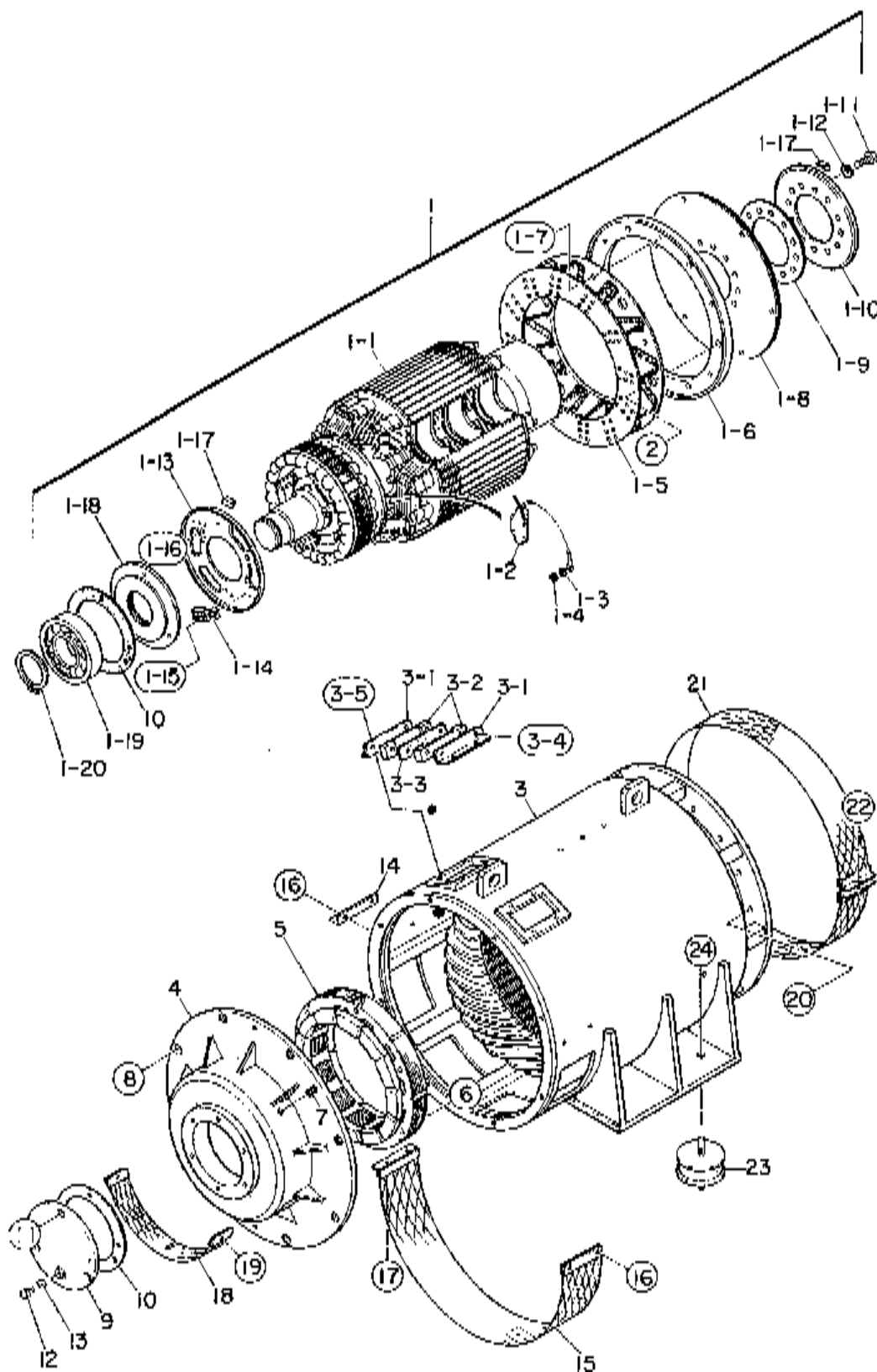

DCA-500SSK — GENERATOR ASSY.

GENERATOR ASSY.

<u>NO</u>	<u>PART NO</u>	<u>PART NAME</u>	<u>QTY.</u>	<u>REMARKS</u>
9	7431310003	COVER, BEARNG	1	
10	8461312004	GASKET, BEARING	2	
11	0010108095	HEX. HEAD BOLT	3	
	0040008000	LOCK WASHER	3	
	0041208000	PLAIN WASHER	3	
12	0010110016	HEX. HEAD BOLT	1	
13	0803000104	PACKING	1	
14	8461335004	BRACKET, COVER	1	
15	8461334003	COVER, STATOR	1	
16	0017106012	HEX. HEAD BOLT	4	
17	0017106050	HEX. HEAD BOLT	2	
18	8461333003	COVER, EXCITER	1	
19	0017106012	HEX. HEAD BOLT	2	
20	0012112040	HEX. HEAD BOLT	16	
	0042512000	LOCK WASHER	16	
21	8461332003	COVER, FAN	1	
22	0017106050	HEX. HEAD BOLT	1	
23	0605000012	RUBBER SUSPENSION	4	
24	0030020000	HEX. NUT	8	
	0040020000	LOCK WASHER	8	

DCA-500SSK — CONTROL BOX ASSY.

CONTROL BOX ASSY.

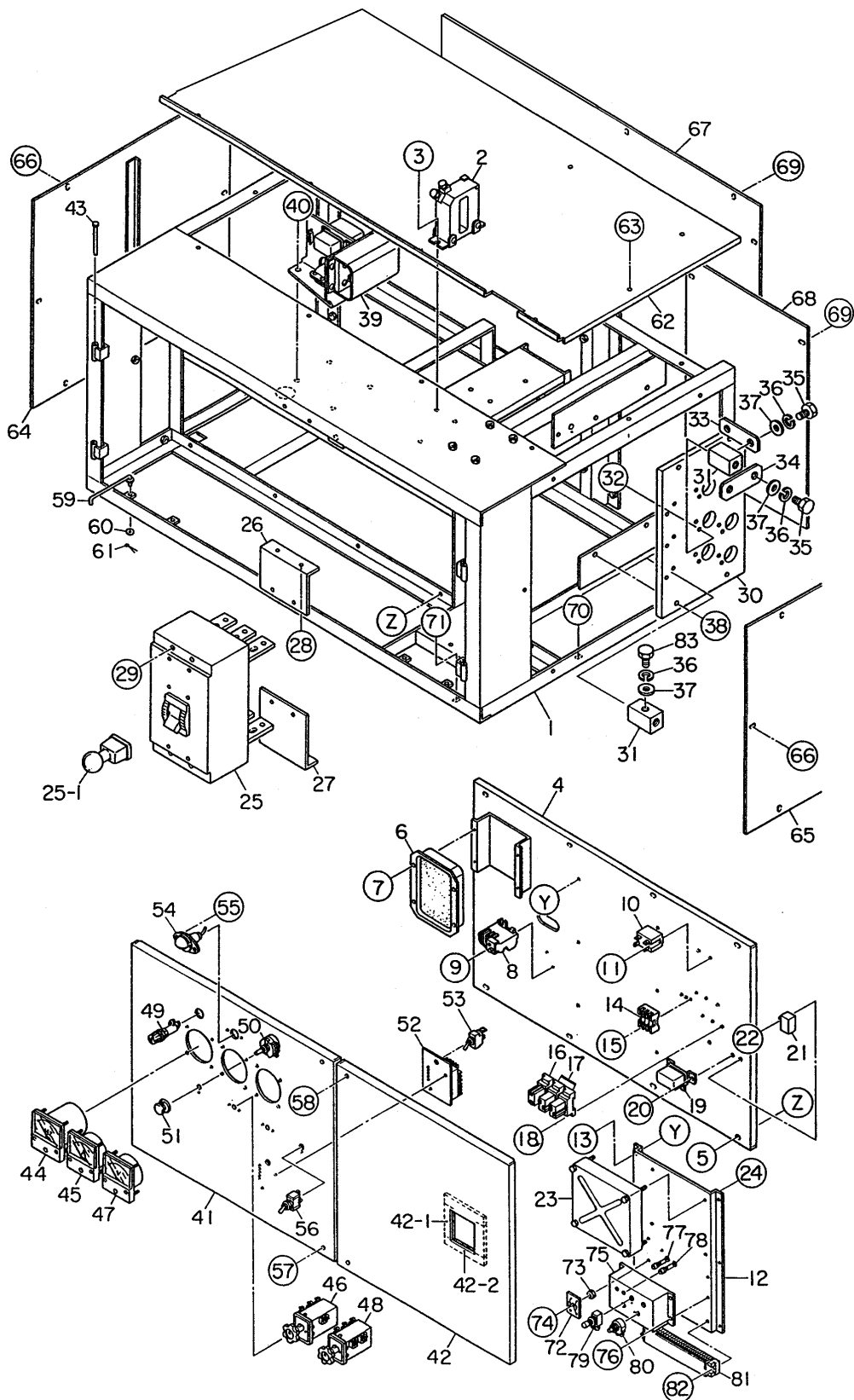

DCA-500SSK — CONTROL BOX ASSY.

CONTROL BOX ASSY.

<u>NO</u>	<u>PART NO</u>	<u>PART NAME</u>	<u>QTY.</u>	<u>REMARKS</u>
1	8481812502	CONTROL BOX	1	
2	0601801194	CURRENT TRANSFORMER, AMMETER	3	CW-40LM 1000/5A
3	0017108020	HEX. HEAD BOLT	6	
4	C4261501303	SET PANEL, ELECTRIC PARTS	1	
5	0017108030	HEX. HEAD BOLT	8	
6	0601820625	AUTOMATIC VOLTAGE REGULATOR	1	NTA5A2T
7	0027105016	MACHINE SCREW	4	
8	0601820892	OVER CURRENT RELAY	1	THN20HZKP
9	0027104016	MACHINE SCREW	2	
10	0601823706	RELAY	1	
11	0027104014	MACHINE SCREW	2	
12	0601823861	ENGINE STOP UNIT	1	MSA9014
13	0027104014	MACHINE SCREW	2	
14	0601802133	FUSE, LEFT SIDE	1	5A
	0601802164	FUSE	1	30A
	0601802149	FUSE, RIGHT SIDE	1	10A
	0601802218	HOLDER, FUSE	1	F7111SP
15	0021004020	MACHINE SCREW	3	
	0040004000	LOCK WASHER	3	
	0041204000	PLAIN WASHER	3	
16	0601823757	RELAY	1	MY2DC24V
	PYF08A	SOCKET	1	REPLACES 0601823143
	PYCA1	HOLDER	1	REPLACES 0601824400
17	MY4DC24V	RELAY	2	REPLACES 0601823759
	PYF14A	SOCKET	2	REPLACES 0601823146
	PYCA1	HOLDER	2	REPLACES 0601824400
18	0027104016	MACHINE SCREW	6	
19	0602201246	RELAY	1	1750733520
20	0017105016	HEX. HEAD BOLT	2	
21	0602201911	UNIT, BATTERY SENSOR	1	C7038A0000
22	0017106020	HEX. HEAD BOLT	1	
23	0602200446	EMERGENCY RELAY	1	6008151252
24	0017106016	HEX. HEAD BOLT	4	
25	0601807031	CIRCUIT BREAKER	1	XS1600NA1400A
25-1	0601802525	HANDLE, CIRCUIT BREAKER	1	XHA9
26	7971816104	BRACKET, CIRCUIT BREAKER	1	
27	7971816304	BRACKET, CIRCUIT BREAKER	1	
28	0017108020	HEX. HEAD BOLT	4	
29	0021008045	MACHINE SCREW	4	
	0030008000	HEX. NUT	4	
	0040008000	LOCK WASHER	4	
	0041208000	PLAIN WASHER	4	
30	7461861113	CHANGE-OVER BOARD, VOLTAGE	1	
31	7431852104	CHANGE TERMINAL	10	
32	0017108035	HEX. HEAD BOLT	20	
33	7971852504	TERMINAL PLATE	7	
34	7431853104	CHANGE PLATE	7	
35	0801832504	HEX. HEAD BOLT	17	
36	0040020000	LOCK WASHER	20	
37	0041420000	PLAIN WASHER	20	
38	0010110040	HEX. HEAD BOLT	4	
	0030010000	HEX. NUT	4	
	0040010000	LOCK WASHER	4	
	0041210000	PLAIN WASHER	4	

DCA-500SSK — CONTROL BOX ASSY.

CONTROL BOX ASSY.

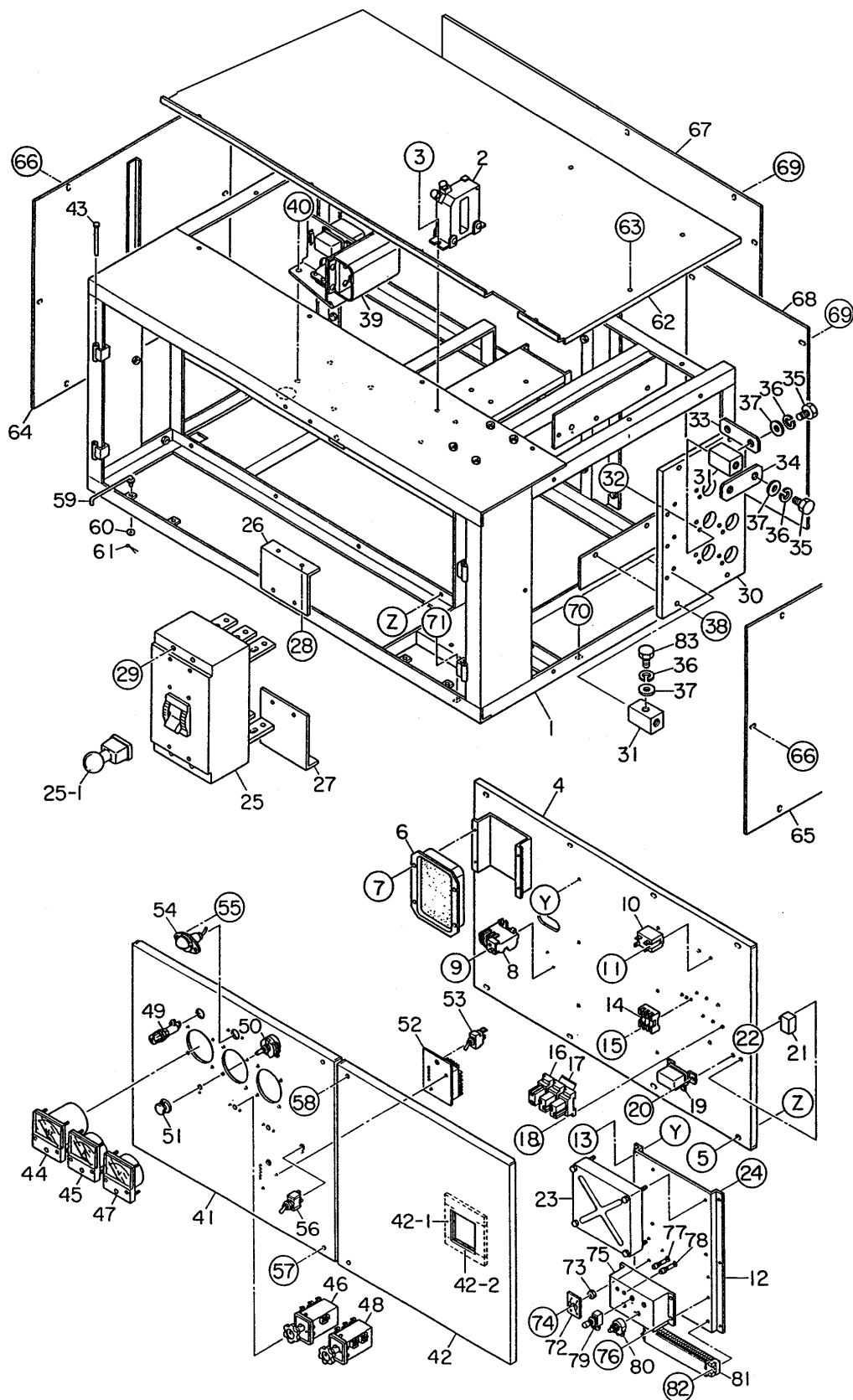

DCA-500SSK — CONTROL BOX ASSY.

CONTROL BOX ASSY.

<u>NO</u>	<u>PART NO</u>	<u>PART NAME</u>	<u>QTY.</u>	<u>REMARKS</u>
39	0602201245	APS UNIT	1	6008153600
40	0010010040	HEX.HEAD BOLT	4	
	0040010000	LOCK WASHER	4	
	0041210000	PLAIN WASHER	4	
41	C4224001403	CONTROL PANEL	1	
42	7971822603	CONTROL PANEL	1	
42-1	0228800124	RUBBER SEAL	2	
42-2	0228800100	RUBBER SEAL	2	
43	0605011211	PIN	4	
44	0601800480	FREQUENCY METER	1	PAL100 220V 45~65Hz
45	0601800780	AC AMMETER	1	PSK100 0~1000A 0~2000A
46	0601801040	CHANGE OVER SWITCH, AMMETER	1	SL2AS
47	0601800252	AC VOLTMETER	1	PCK100 0~600V
48	0601801041	CHANGE OVER SWITCH, VOLTMETER	1	SL2VS
49	0601810072	PILOT LAMP	1	LP132DC 220V
	0601810261	BULB	1	
50	061840073	RHEOSTAT	1	RA20A2SE102BJ
51	0601840121	KNOB	1	
52	0601827395	ENGINE CONTROLLER	1	ECU88LG24
53	061831340	SWITCH	1	82608DPDT
54	0601810161	PANEL LIGHT	1	V325070
	0601810214	BULB	1	
55	0207004000	HEX. NUT	2	
56	0601830710	SWITCH, PANEL LIGHT	1	S301T
57	C9221100004	HEX. HEAD BOLT	2	
	0040008000	LOCK WASHER	2	
	0041208000	PLAIN WASHER	2	
	0080200007	SNAP RING	2	
58	C9221100004	HEX. HEAD BOLT	2	
	0040008000	LOCK WASHER	2	
	0041208000	PLAIN WASHER	2	
	0080200007	SNAP RING	2	
59	3871824004	STOPPER, CONTROL PANEL	2	
60	0041206000	PLAIN WASHER	2	
61	0605010502	SNAP PIN	2	
62	8481814503	COVER, CONTROL BOX	1	
63	0017108020	HEX. HEAD BOLT	10	
64	8481812104	SIDE PANEL, CONTROL BOX	1	
65	7971812104	SIDE PANEL, CONTROL BOX	1	
66	0017108020	HEX. HEAD BOLT	12	
67	8481825104	PANEL, CONTROL BOX	1	
68	8481825304	PANEL, CONTROL BOX	1	
39	0017108020	HEX. HEAD BOLT	15	
70	0017110030	HEX. HEAD BOLT	5	
71	0017108020	HEX. HEAD BOLT	3	
72	0801830904	HEX. HEAD BOLT	3	

DCA-500SSK — ENGINE & RADIATOR ASSY.

ENGINE & RADIATOR ASSY.

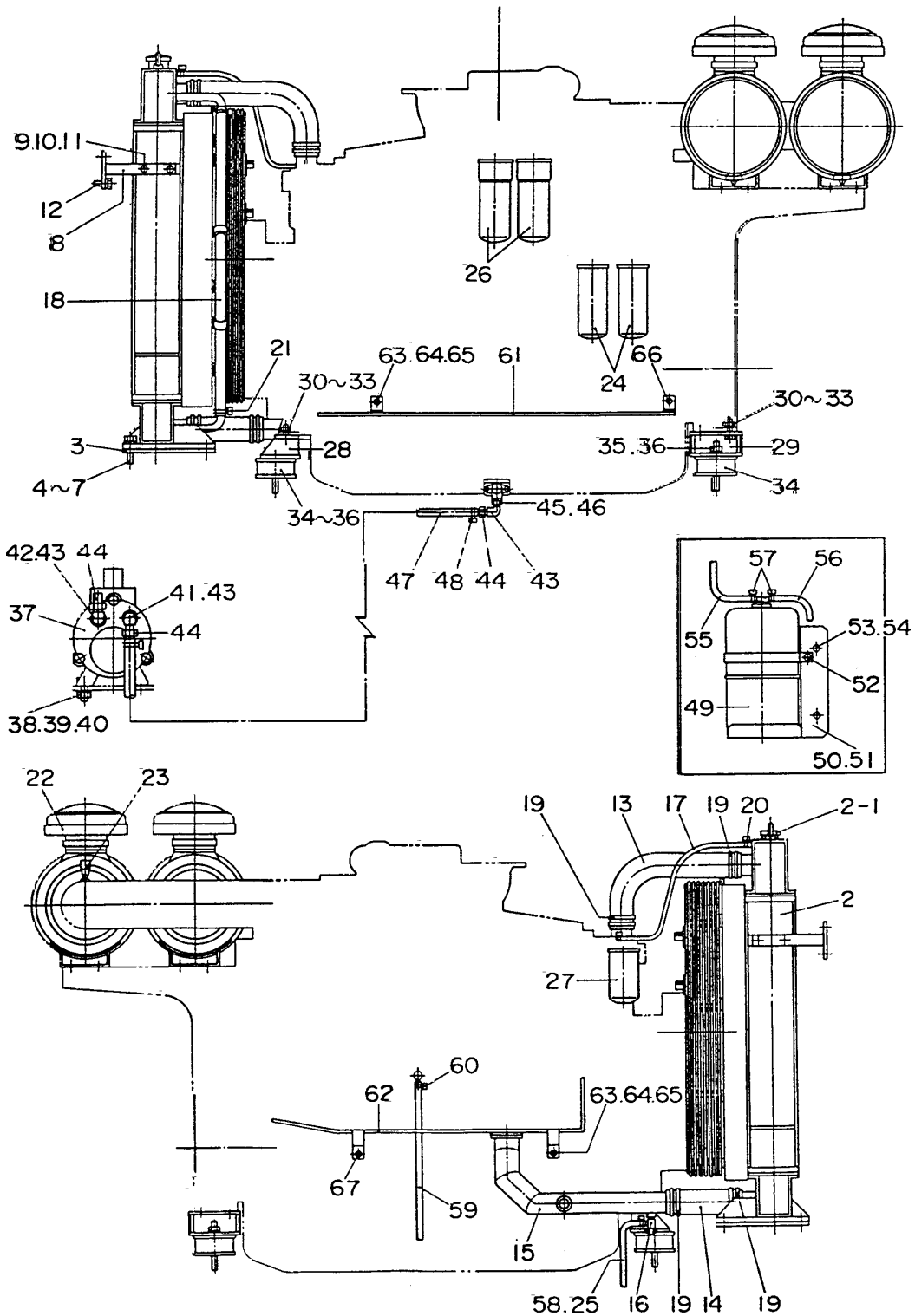

DCA-500SSK — ENGINE & RADIATOR ASSY.

ENGINE & RADIATOR ASSY.

<u>NO</u>	<u>PART NO</u>	<u>PART NAME</u>	<u>QTY.</u>	<u>REMARKS</u>
1	C4925200004	ENGINE	1	KOMATSU SA6D170BE-1
2	0602011985	RADIATOR	1	6162639151
2-1	0602011058	CAP, RADIATOR	1	23S0311150
3	0605000085	RUBBER SHEET	2	6995619230
4	0010120100	HEX. HEAD BOLT	4	
5	0030020000	HEX. NUT	8	
6	0040020000	LOCK WASHER	4	
7	0041220000	PLAIN WASHER	8	
8	8485123004	BRACKET, RADIATOR	2	
9	0010112025	HEX. HEAD BOLT	4	
10	0040012000	PLAIN WASHER	4	
11	0041212000	PLAIN WASHER	4	
12	0017110025	HEX. HEAD BOLT	4	
13	0602013955	RADIATOR HOSE	1	6995621450
14	0602014649	RADIATOR HOSE	1	6162639650
15	0602013305	RADIATOR PIPE	1	6162639640
16	0602012054	DRAIN VALVE	1	07730500004
17	0602014541	RADIATOR HOSE	1	0726120911
18	0602013954	RADIATOR HOSE	1	6128619650
19	0602014350	HOSE BAND	8	0728101029
20	0602014058	HOSE BAND	2	0728100197
21	0602014351	HOSE BAND	2	0728100489
22	0602040156	ELEMENT, AIR CLEANER	2	6125817032
23	0602040647	DUST SENSOR	1	6008157930
24	0602041146	CARTRIDGE, OIL FILTER	2	6002111231
25	0602042146	CARTRIDGE, FUEL FILTER	3	6003118293
26	0602045149	CARTRIDGE, CORROSION RESISTOR....	1	6004111161
27	7435112004	ENGINE FOOT	1	
28	8485112004	ENGINE FOOT	2	
29	0010118060	HEX. HEAD BOLT	6	
30	0030018000	HEX. NUT	6	
31	0040018000	LOCK WASHER	6	
32	0041218000	PLAIN WASHER	6	
33	0605000012	RUBBER SUSPENSION	4	
34	0030020000	HEX. NUT	8	
35	0040020000	LOCK WASHER	8	
36	0602023160	PUMP	1	GM2524H
37	0010108025	HEX. HEAD BOLT	4	
38	0041208000	PLAIN WASHER	4	
39	0207008000	HEX. NUT	4	

DCA-500SSK — ENGINE & RADIATOR ASSY.

ENGINE & RADIATOR ASSY.

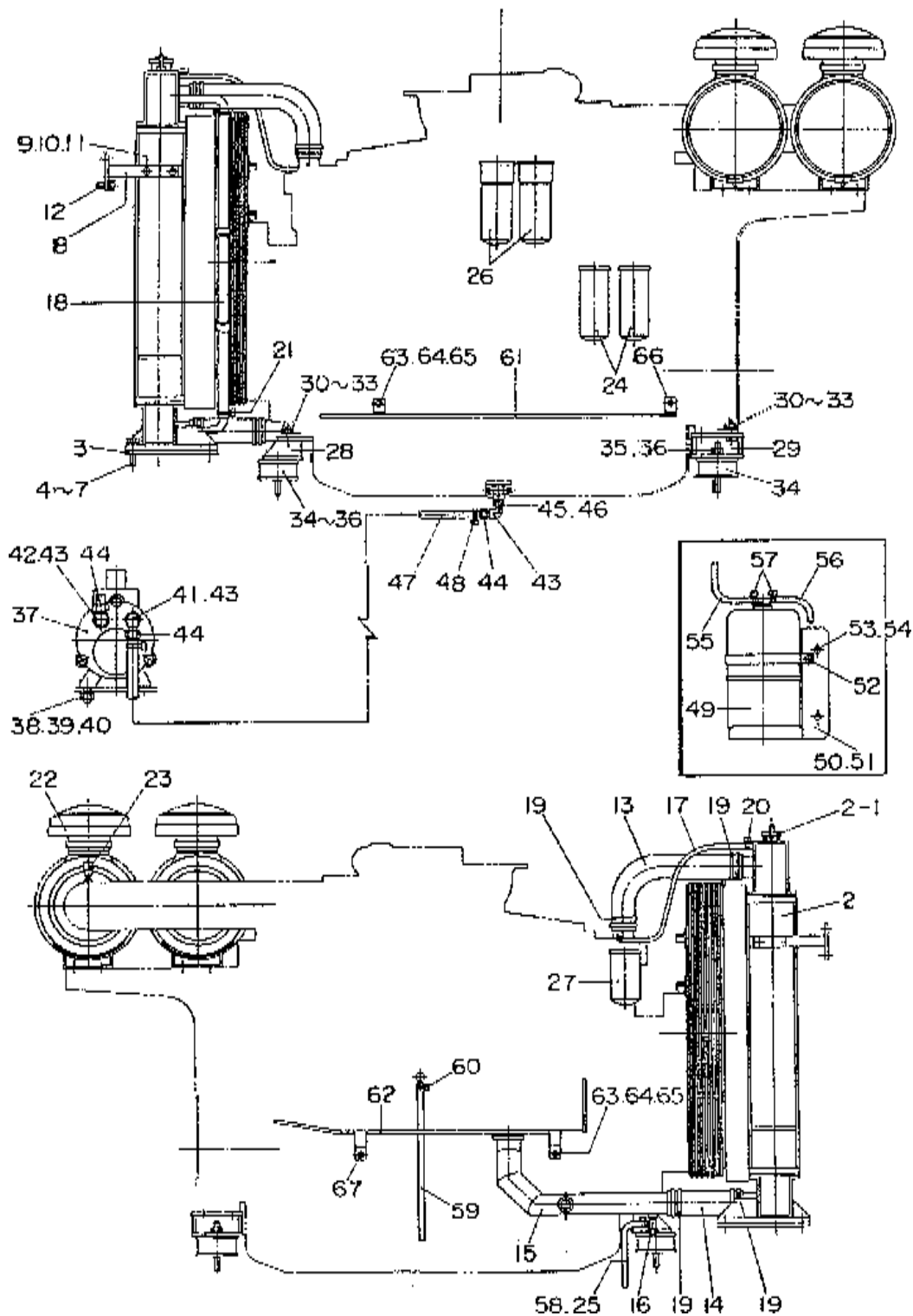

DCA-500SSK — ENGINE & RADIATOR ASSY.

ENGINE & RADIATOR ASSY.

<u>NO</u>	<u>PART NO</u>	<u>PART NAME</u>	<u>QTY.</u>	<u>REMARKS</u>
40	0131710060	BUSHING	1	
41	0131708060	BUSHING	1	
42	0130206000	STREET ELBOW	3	
43	0602022202	HOSE JOINT	1	
45	0802024004	PACKING	1	
46	0191601350	HOSE	1	
47	0605515134	HOSE BAND	2	
48	0602010230	RESERVE TANK	10228104860
49	8482082103	BRACKET, RESERVE TANK	1	
50	0229200700	RUBBER CUSHION	1	
51	0017106030	HEX. HEAD BOLT	1	
52	0017108020	HEX. HEAD BOLT	2	
53	0199601100	HOSE	1	
54	0194001600	HOSE	1	
55	0605515013	HOSE BAND	3	
56	0602014648	HOSE	10727061510
57	0194201000	HOSE	1	
58	0605515014	HOSE BAND	2	
59	8482256304	CLAMPER ROD	1	
60	8482256104	CLAMPER ROD	1	
61	0010118040	HEX. HEAD BOLT	2	
62	0040018000	LOCK WASHER	2	
63	0041218000	PLAIN WASHER	2	
64	0017110025	HEX. HEAD BOLT	1	
65	0017112025	HEX. HEAD BOLT	1	
66	C4494600004	RUBBER SEAL	1	

DCA-500SSK — ENGINE OPERATING PANEL ASSY.

ENGINE OPERATING PANEL ASSY.

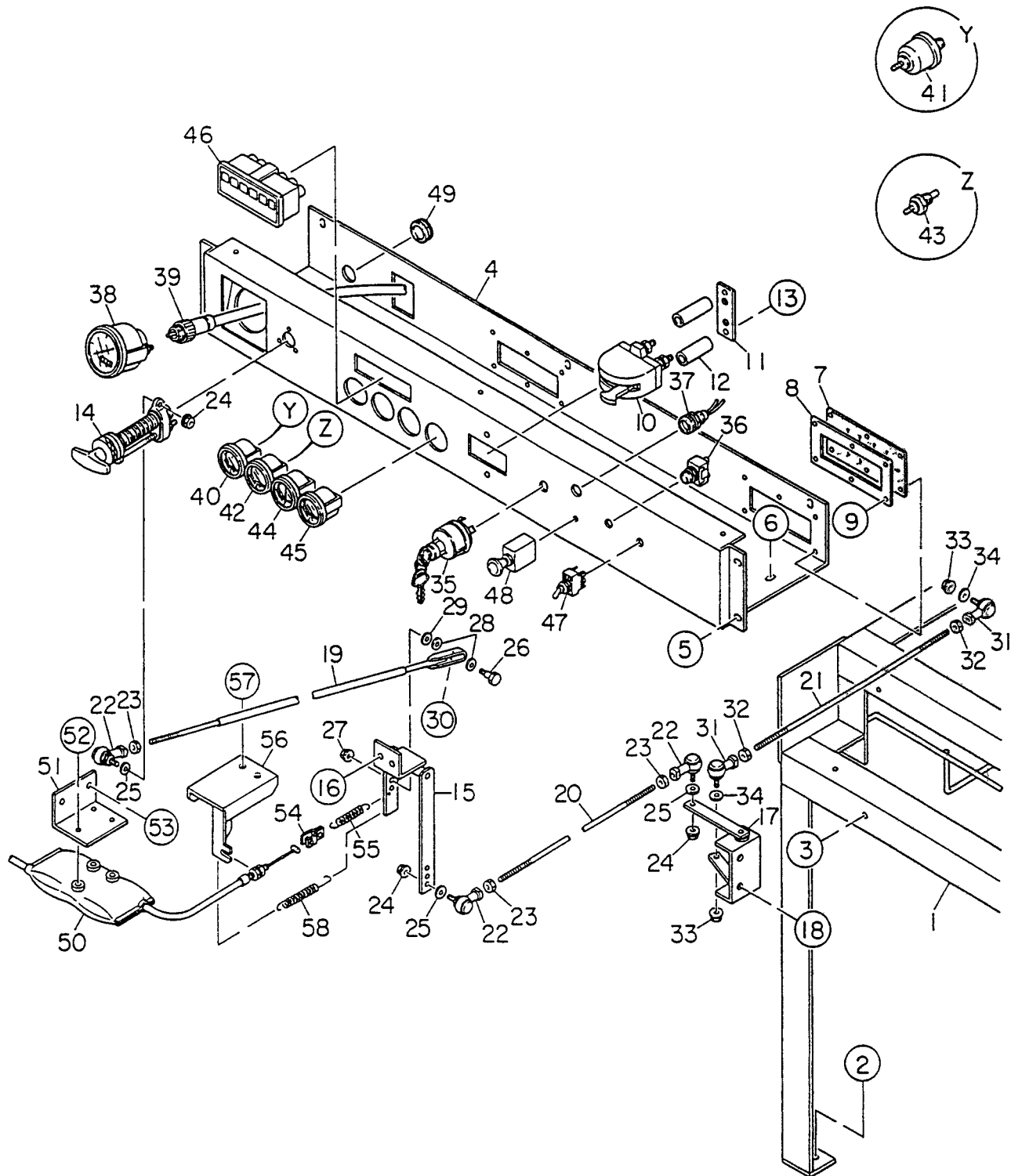

DCA-500SSK — ENGINE OPERATING PANEL ASSY.

ENGINE OPERATING PANEL ASSY.

<u>NO</u>	<u>PART NO</u>	<u>PART NAME</u>	<u>QTY.</u>	<u>REMARKS</u>
1	8485312002	SUPPORT LEG	1	
2	0010012035	HEX. HEAD BOLT	4	
	0030012000	HEX. NUT	4	
	0040012000	LOCK WASHER	4	
	0041212000	PLAIN WASHER	4	
3	0017110025	HEX. HEAD BOLT	2	
4	C4352100403	OPERATING PANEL	1	
5	0017108020	HEX. HEAD BOLT	4	
6	0017108020	HEX. HEAD BOLT	6	
7	8085182004	RUBBER COVER	2	
8	8085183004	SET FRAME, RUBBER COVER	2	
9	0017106020	HEX. HEAD BOLT	12	
10	0602101012	BATTERY SWITCH	1	0315262002
11	0805008804	SET PLATE, BATTERY SWITCH	1	
12	0805008704	STAY, BATTERY SWITCH	2	
13	0020008070	MACHINE SCREW	2	
	0040008000	LOCK WASHER	2	
	0041208000	PLAIN WASHER	2	
14	0840201200	THROTTLE HANDLE	1	
15	8482181103	LINK, GOVERNOR ROD	1	
16	0017110030	HEX. HEAD BOLT	2	
	0207010000	HEX. NUT	2	
17	7472181003	LINK, GOVERNOR ROD	1	
18	0017112030	HEX. HEAD BOLT	2	
19	8482152104	GOVERNOR ROD	1	
20	8482152004	GOVERNOR ROD	1	
21	8482152204	GOVERNOR ROD	1	
22	0602180106	BALL JOINT	3	
23	0030008000	HEX. NUT	3	
24	0207006000	HEX. NUT	3	
25	0041206000	PLAIN WASHER	3	
26	0802100704	PIN BOLT	1	
27	0207006000	HEX. NUT	3	
28	0041208000	PLAIN WASHER	2	
29	0041206000	PLAIN WASHER	1	

DCA-500SSK — ENGINE OPERATING PANEL ASSY.

ENGINE OPERATING PANEL ASSY.

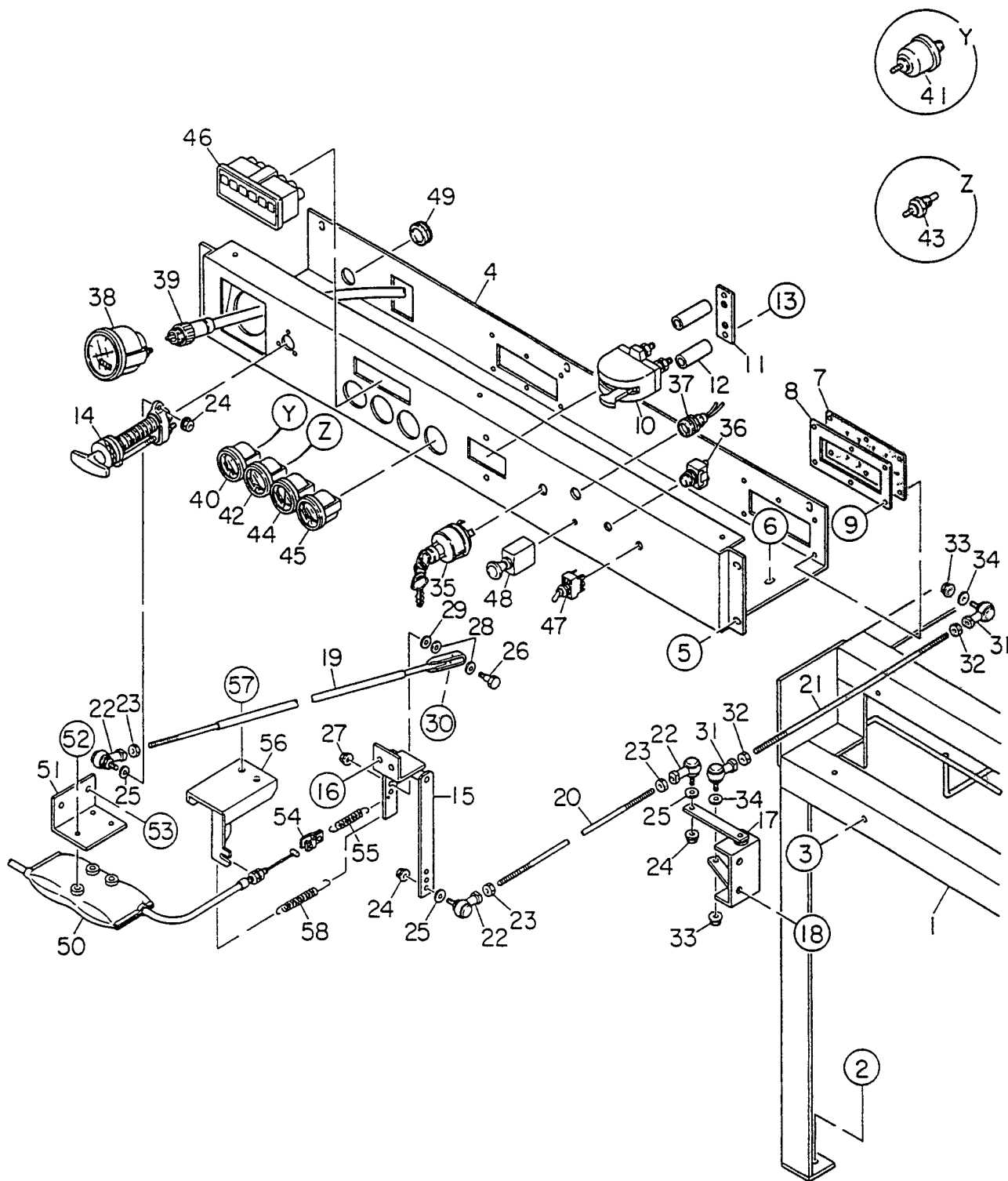

DCA-500SSK — ENGINE OPERATING PANEL ASSY.

ENGINE OPERATING PANEL ASSY.

<u>NO</u>	<u>PART NO</u>	<u>PART NAME</u>	<u>QTY.</u>	<u>REMARKS</u>
30	0027105016	MACHINE SCREW	1	
31	0602180105	BALL JOINT	2	
32	0030008000	HEX. NUT	2	
33	0207008000	HEX. NUT	2	
34	0041208000	PLAIN WASHER	2	
35	0602100049	STARTER SWITCH	1	6008155390
36	0602104045	EMERGENCY STOP BUTTON	1	0804610000
37	0602103043	PREHEAT INDICATOR	1	0814721200
38	0602120054	TACHOMETER	1	25000KX4110
39	0602120165	CABLE, TACHOMETER	1	62500KA8610
40	0602122060	OIL PRESSURE GAUGE	1	42000KX1410
41	0602122203	UNIT, OIL PRESSURE	1	53600KX0501
42	0602123061	WATER TEMPERATURE GAUGE	1	4000KX0910
43	0602123206	UNIT, WATER TEMPERATURE	1	51400KS0600
44	0602121052	CHARGE AMMETER	1	43000KV0300
45	0602125060	FUEL GAUGE	1	41000KW0110
46	0602115014	OK MONITOR	1	V3376600000
47	0601830715	ENGINE SPEED SWITCH	1	S332T
48	0602210649	PREHEATING SWITCH	1	0806130070
49	0601850267	GROMMET	1	SG30A
50	0602210809	CONTROLLER	1	181900193Z
51	8492233004	BRACKET	1	
52	0027106012	MACHINE SCREW	3	
53	0017108025	HEX. HEAD BOLT	2	
	0207008000	HEX. NUT	2	
54	0802100204	JOINT	1	
55	0802101204	SPRING	1	
56	8482159304	BRACKET	1	
57	00171010025	HEX. HEAD BOLT	2	
58	3335048004	SPRING	1	

DCA-500SSK — OUTPUT TERMINAL ASSY.

OUTPUT TERMINAL ASSY.

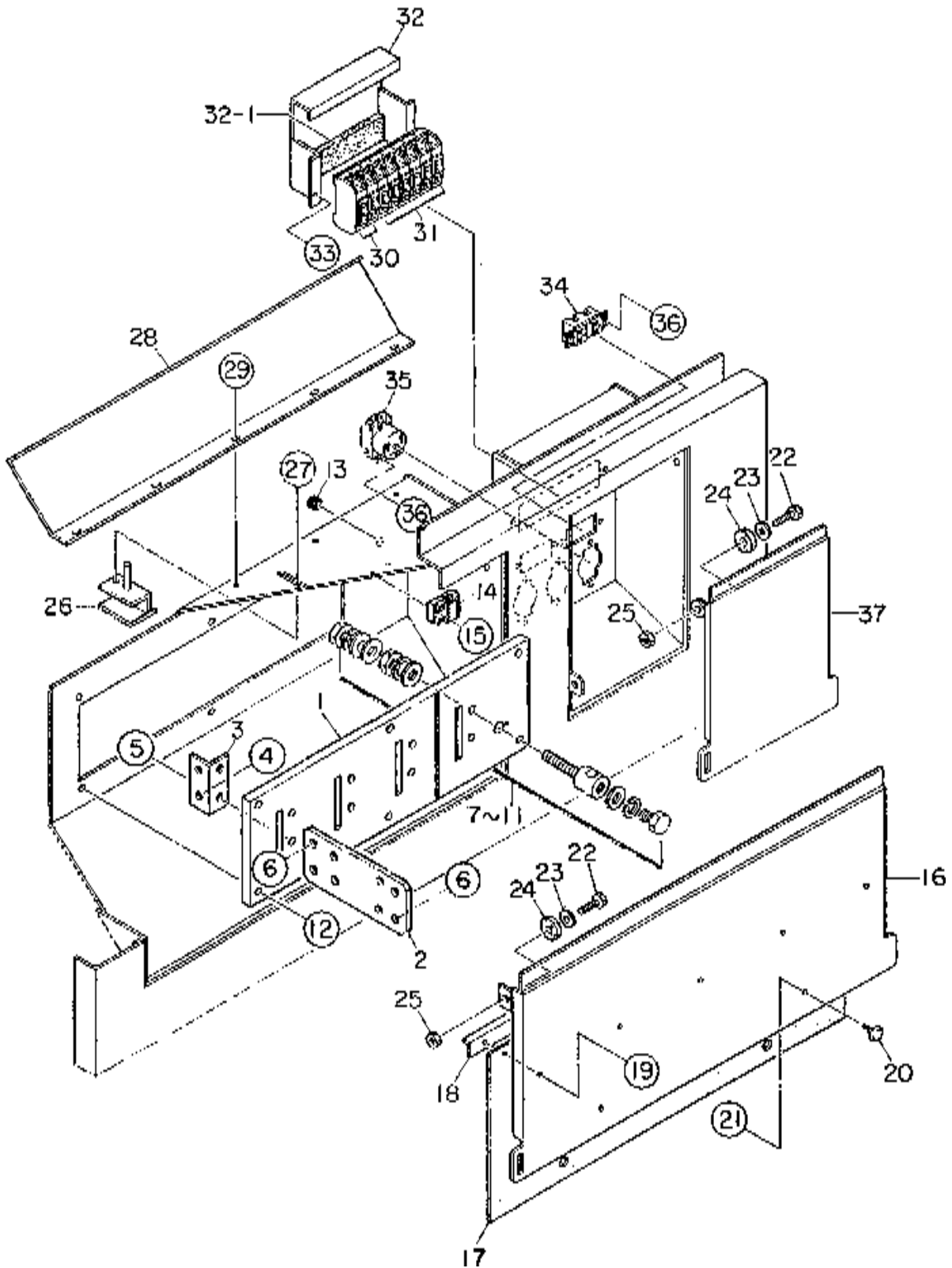

DCA-500SSK — OUTPUT TERMINAL ASSY.

OUTPUT TERMINAL ASSY.

<u>NO</u>	<u>PART NO</u>	<u>PART NAME</u>	<u>QTY.</u>	<u>REMARKS</u>
1	C4231700603	SET BOARD, OUTPUT TERMINAL	1	
2	7521860504	OUTPUT TERMINAL	4	
3	7521850504	BRACKET, OUTPUT TERMINAL	4	
4	0010112040	HEX. HEAD BOLT	8	
	0030012000	HEX. NUT	8	
	0040012000	LOCK WASHER	8	
	0041212000	PLAIN WASHER	16	
5	0010112045	HEX. HEAD BOLT	8	
	0030012000	HEX. NUT	8	
	0040012000	LOCK WASHER	8	
	0041212000	PLAIN WASHER	8	
6	0010112040	HEX. HEAD BOLT	24	
	0030012000	HEX. NUT	24	
	0040012000	LOCK WASHER	24	
	0041212000	PLAIN WASHER	48	
7	0801830404	TERMINAL	1	
8	0801830904	HEX. HEAD BOLT	1	
9	0039320000	HEX. NUT	2	
10	0040020000	LOCK WASHER	3	
11	0041420000	PLAIN WASHER	4	
12	0010112050	HEX. HEAD BOLT	6	
	0030012000	HEX. NUT	6	
	0040012000	LOCK WASHER	6	
	0041212000	PLAIN WASHER	12	
13	0601850275	GROMMET	1	
14	0601815324	TERMINAL BOARD	1	TS22P
15	0027104020	MACHINE SCREW	2	
16	C4237101304	COVER, OUTPUT TERMINAL	1	
17	7971867114	RUBBER SHEET	1	
18	7521865804	SET PANEL, RUBBER SHEET	1	
19	0019106020	HEX. HEAD BOLT	5	
	0042306000	LOCK WASHER	5	
	0042406000	PLAIN WASHER	5	
20	0605010660	KNOB	2	KMM21xM6
21	0207006000	HEX. NUT	2	
22	0010112045	HEX. HEAD BOLT	4	
23	0041212000	PLAIN WASHER	4	
24	0805009804	STAY RUBBER	4	
25	0030012000	HEX. NUT	4	
26	7521865603	STOPPER	1	

DCA-500SSK — OUTPUT TERMINAL ASSY.

OUTPUT TERMINAL ASSY.

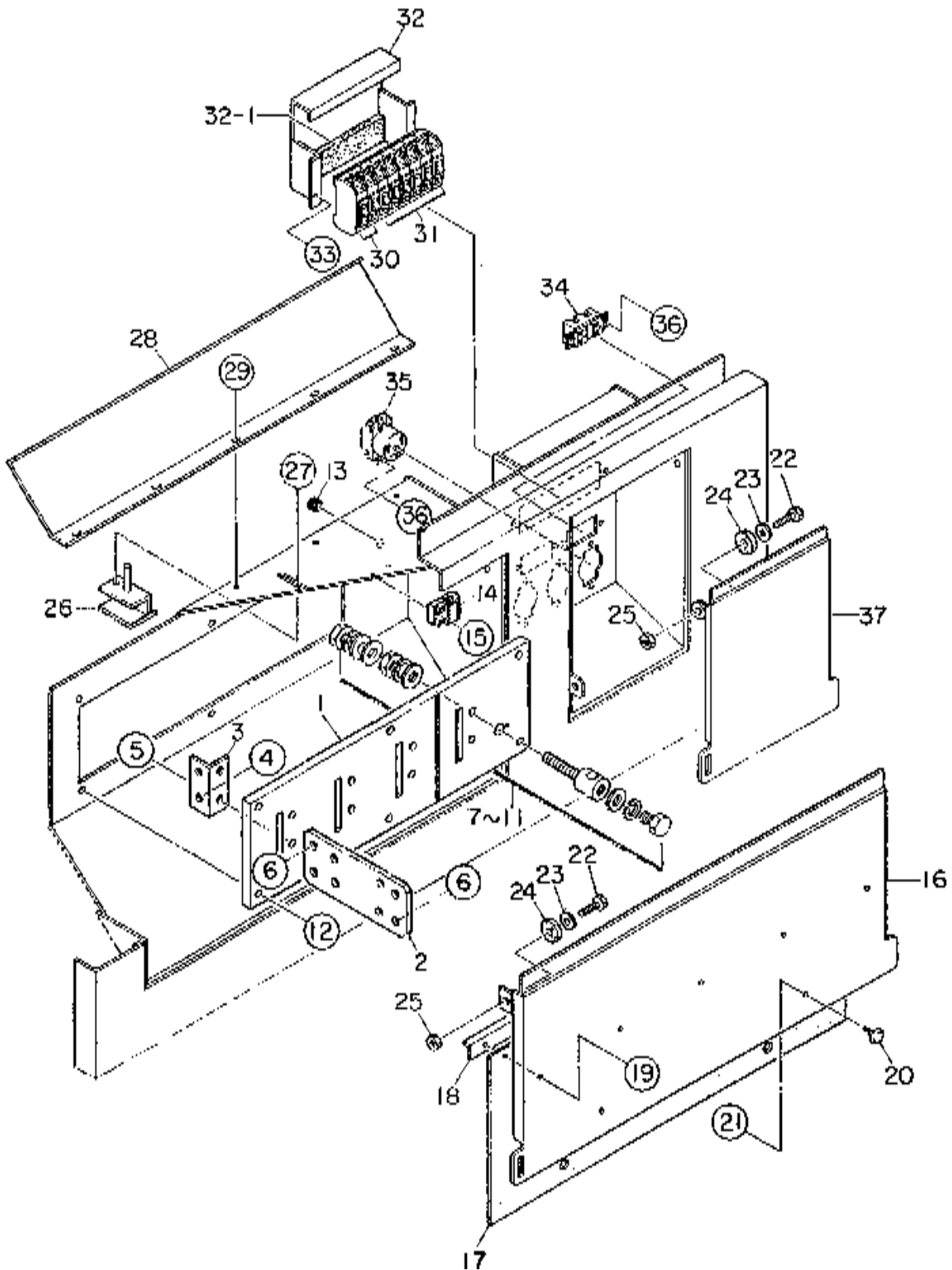

DCA-500SSK — OUTPUT TERMINAL ASSY.

OUTPUT TERMINAL ASSY.

<u>NO</u>	<u>PART NO</u>	<u>PART NAME</u>	<u>QTY.</u>	<u>REMARKS</u>
27	0010108030	HEX. HEAD BOLT	1	
	0030008000	HEX. NUT	1	
	0041208000	PLAIN WASHER	2	
28	C4237100504	COVER	1	
29	0017108020	HEX. HEAD BOLT	5	
30	0601805313	CIRCUIT BREAKER	2	KM51 265V 20A
31	0601805840	CIRCUIT BREAKER	3	KM52 265V 50A
32	C4261601203	BRACKET, CIRCUIT BREAKER	1	
32-1	0223300200	RUBBER CUSHION	1	
33	0017106030	HEX. HEAD BOLT	2	
34	0601812597	RECEPTACLE	2	GF5352
35	0601812565	RECEPTACLE	3	CS6369
36	0027104015	MACHINE SCREW	10	
	0030004000	HEX. NUT	10	
	0041204000	PLAIN WASHER	10	
37	C4237101203	COVER	1	

DCA-500SSK — BATTERY ASSY.

BATTERY ASSY.

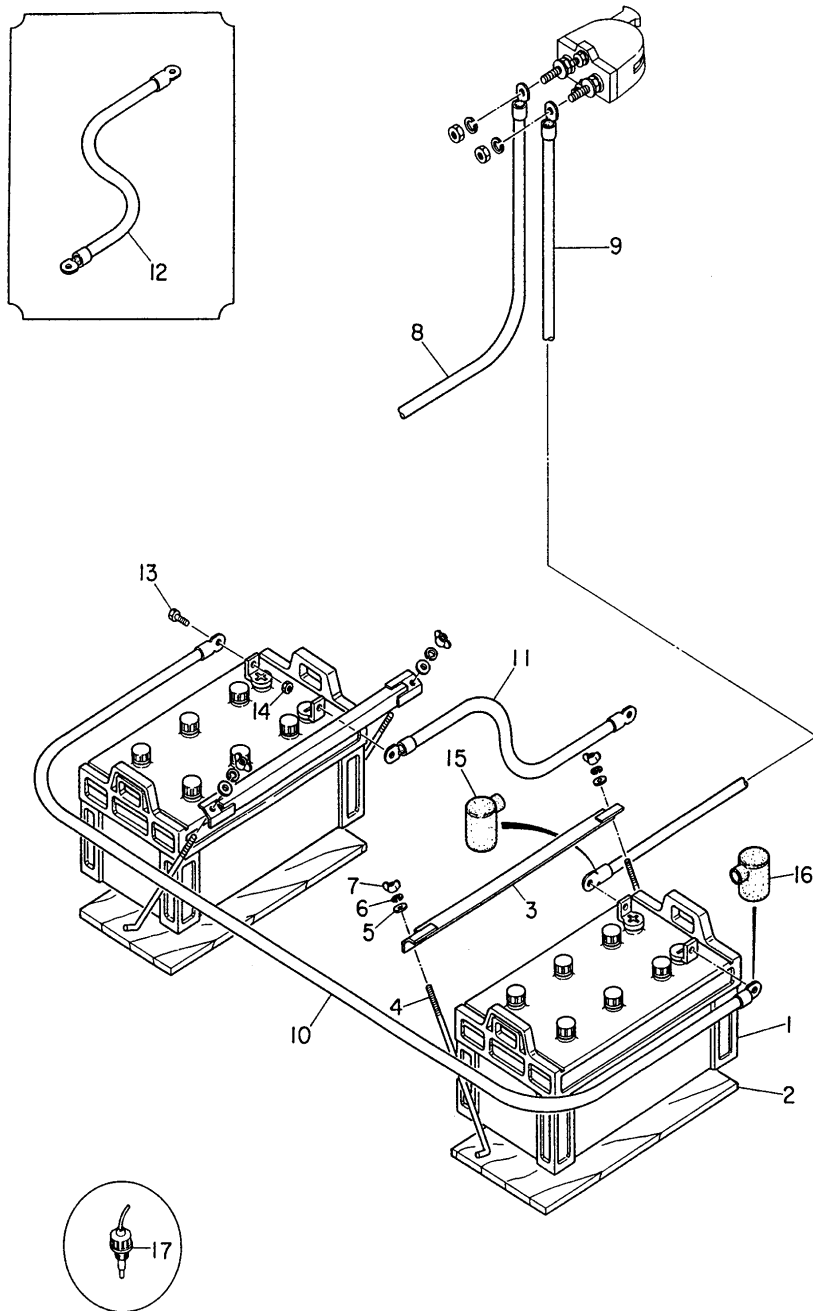

DCA-500SSK — BATTERY ASSY.

BATTERY ASSY.

<u>NO</u>	<u>PART NO</u>	<u>PART NAME</u>	<u>QTY.</u>	<u>REMARKS</u>
1	0168719052	BATTERY	2	190H52
2	0805018904	BATTERY SHEET	2	
3	0805007804	BATTERY BAND	2	
4	0805006504	BATTERY BOLT	4	
5	0037808000	WING NUT	4	
6	0040008000	LOCKWASHER	4	
7	0041208000	PLAIN WASHER	4	
8	8482280104	BATTERY CABLE	1	
9	8482280304	BATTERY CABLE	1	
10	7432280504	BATTERY CABLE	1	
11	7432280904	BATTERY CABLE	1	
12	7432281104	EARTH CABLE	1	
13	0347010030	HEX. HEAD BOLT	4	
14	0208110000	HEX. NUT	4	
15	0845040114	TERMINAL CAP (+)	2	
16	0845041004	TERMINAL CAP (-)	2	
17	0602220205	BATTERY SENSOR	1	

DCA-500SSK — MUFFLER ASSY.

MUFFLER ASSY.

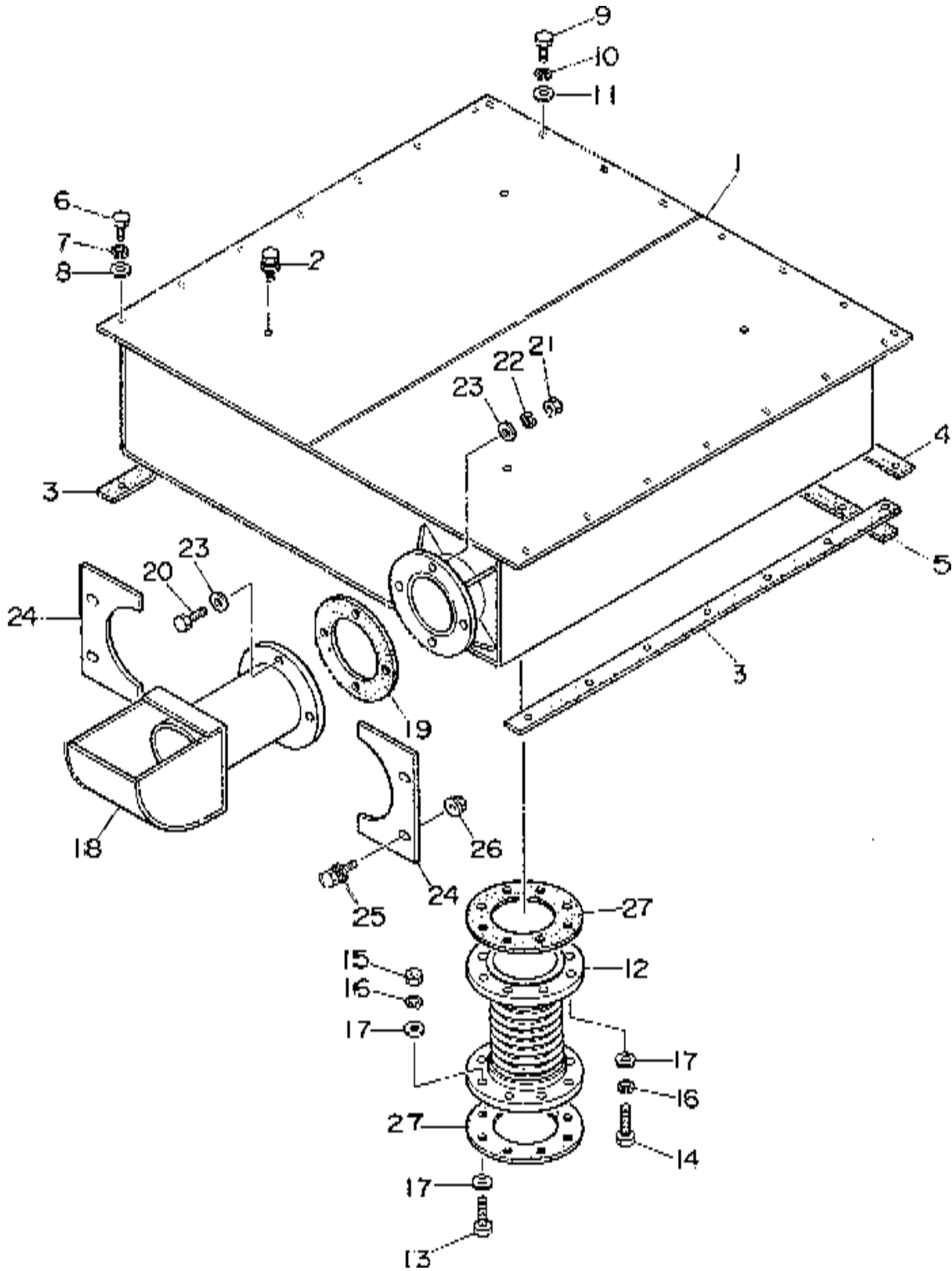

DCA-500SSK — MUFFLER ASSY.

MUFFLER ASSY.

<u>NO</u>	<u>PART NO</u>	<u>PART NAME</u>	<u>QTY.</u>	<u>REMARKS</u>
1	8482311002	MUFFLER	1	
2	0019210020	HEX. HEAD BOLT	4	
3	7432356504	PACKING	2	
4	7432356604	PACKING	1	
5	7432356704	PACKING	1	
6	0019110030	HEX. HEAD BOLT	14	
7	0042310000	LOCKWASHER	14	
8	0042410000	HEX. HEAD BOLT	14	
9	0019108030	HEX. HEAD BOLT	8	
10	0042308000	LOCKWASHER	8	
11	0042408000	PLAIN WASHER	8	
12	C4334000513	EXHAUST PIPE	1	
13	0010116060	HEX. HEAD BOLT	8	
14	0010116050	HEX. HEAD BOLT	8	
16	0040016000	LOCKWASHER	16	
17	0041216000	PLAIN WASHER	24	
18	7472355003	OUTLET PIPE	1	
19	C3334200704	GASKET	1	
20	0010112050	HEX. HEAD BOLT	4	
21	0030012000	HEX. NUT	4	
22	0040012000	LOCKWASHER	4	
23	0041212000	PLAIN WASHER	8	
24	8225125604	COVER	2	
25	0017108020	HEX. HEAD BOLT	4	
26	0207008000	HEX. NUT	4	
27	C4334200504	GASKET	2	

DCA-500SSK — FUEL TANK ASSY.

FUEL TANK ASSY.

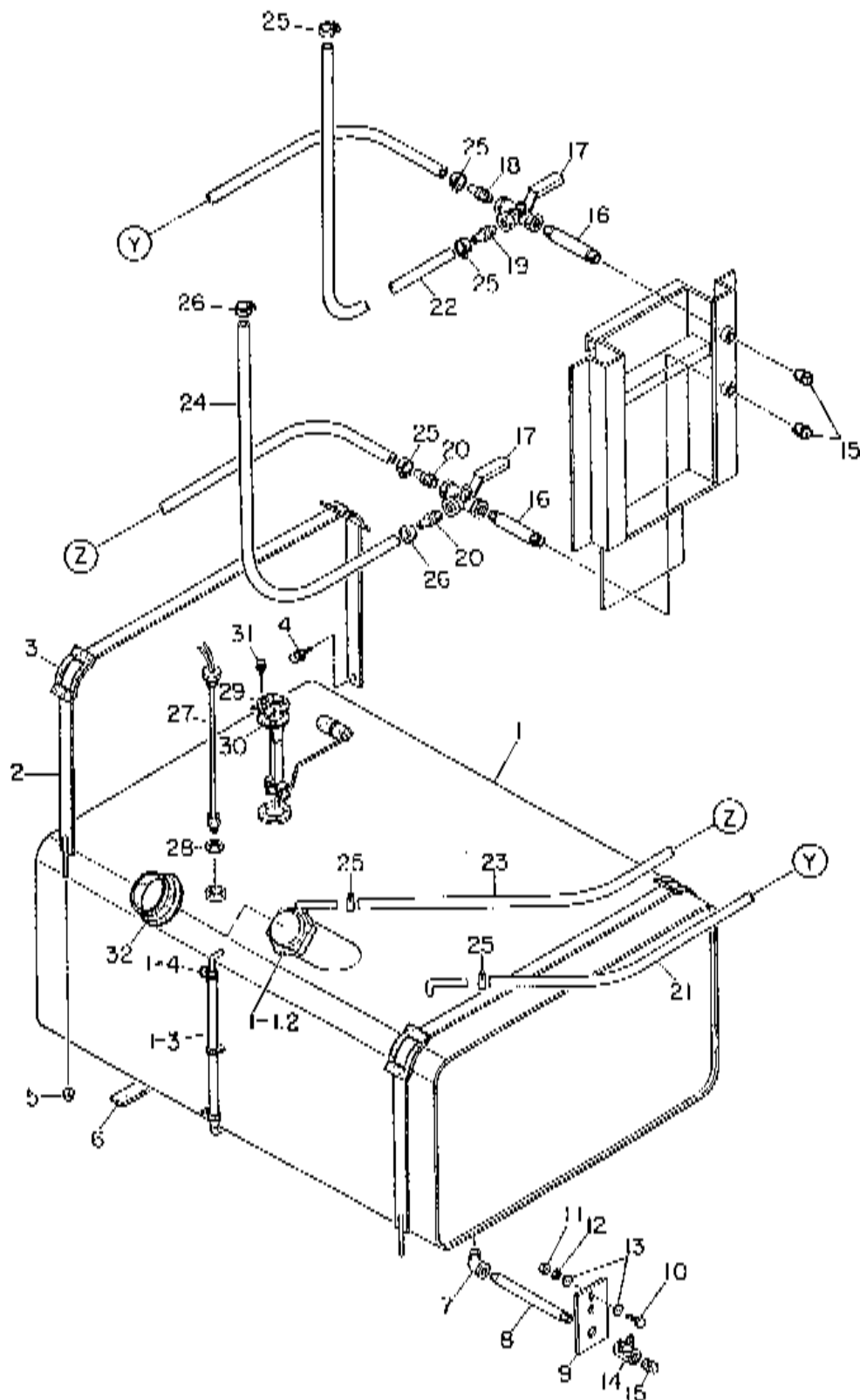

DCA-500SSK — FUEL TANK ASSY.

FUEL TANK ASSY.

<u>NO</u>	<u>PART NO</u>	<u>PART NAME</u>	<u>QTY.</u>	<u>REMARKS</u>
1	C4364000713	FUEL TANK	1	
1-1	0605505005	CAP, FUEL TANK	1	
	0601850505	KEY	1	
1-2	0810105400	FUEL FILTER	1	
1-3	0264100425	HOSE, FUEL GAUGE	1	
1-4	0605515079	HOSE BAND	2	
2	7435523104	TANK BAND	2	
3	0805003414	PAD, TANK BAND	4	
4	0017108020	HEX. HEAD BOLT	2	
5	0207308000	HEX. NUT	2	
6	0221006000	TANK SHEET	6	
7	0130206000	STREET ELBOW	1	
8	7435517114	DRAIN PIPE	1	
9	7525516504	BRACKET	1	
10	0019108030	HEX. HEAD BOLT	2	
11	0205008000	HEX. NUT	2	
12	0042308000	LOCKWASHER	2	
13	0042408000	PLAIN WASHER	4	
14	0603325011	VAVE	1	BBS7715 PT1/2
15	0132006000	PLUG	3	
16	7435512104	LONG NIPPLE	2	
17	0605511033	THREE WAY VALVE	2	400 PT1/2
18	0602022209	HOSE JOINT	1	KH135
19	0602022203	HOSE JOINT	1	KH131
20	7435514304	HOSE JOINT	2	
21	0191403850	SUCTION HOSE	1	
22	0191301100	SUCTION HOSE	1	
23	0191104000	RETURN HOSE	1	
24	0191001800	RETURN HOSE	1	
25	0605515073	HOSE BAND	6	
26	0605515000	HOSE BAND	2	
27	0605503009	FUEL SENSOR	1	
28	0802120604	PACKING	1	
29	0605501050	UNIT, FUEL	1	52000KA9810
30	0602021155	PACKING	1	52391KW3700
31	0022905015	MACHINE SCREW	5	
32	0845039604	RUBBER SEAL	1	

DCA-500SSK — ENCLOSURE #1 ASSY.

ENCLOSURE #1 ASSY.

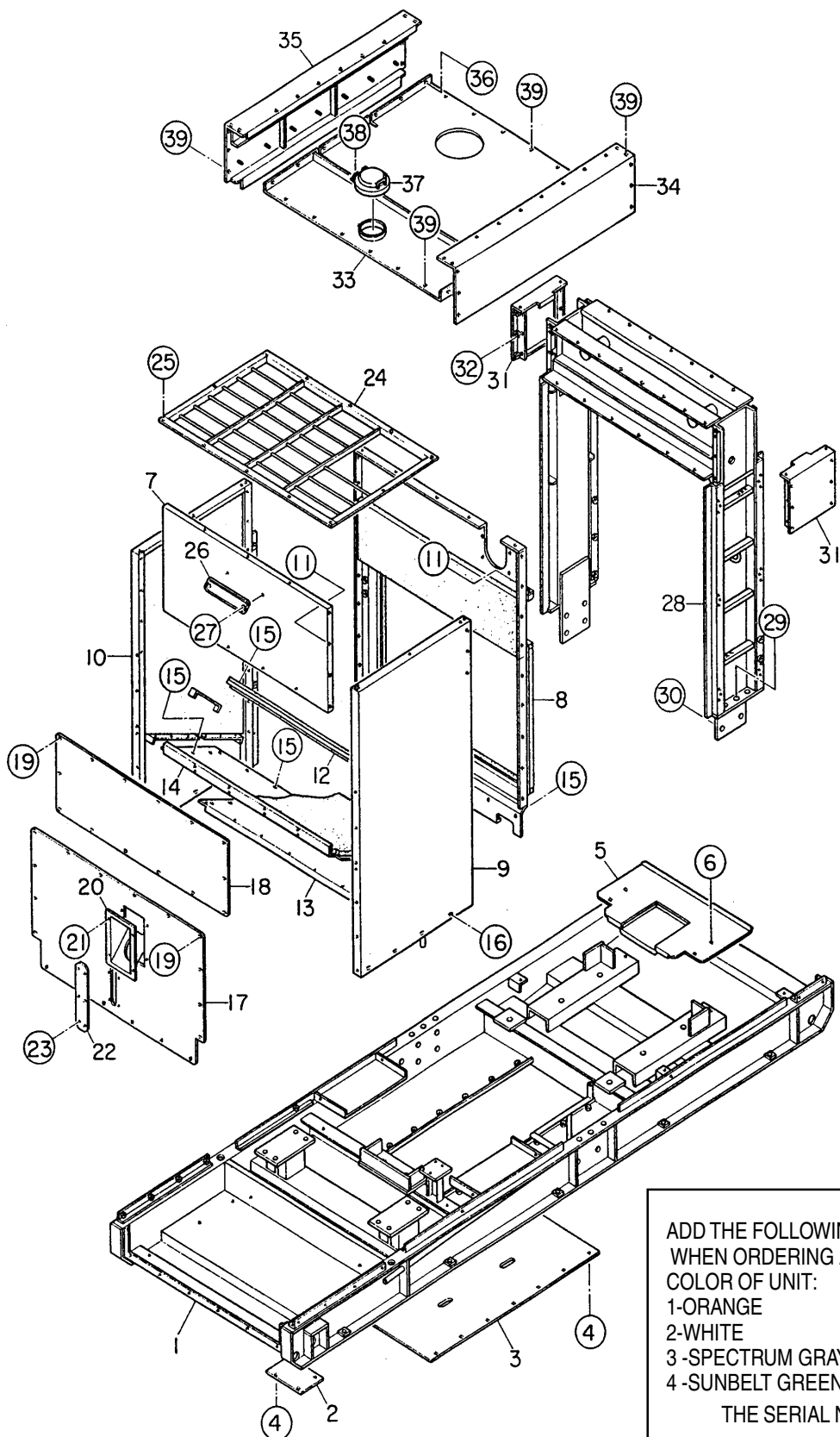

ADD THE FOLLOWING DIGITS AFTER THE PART NUMBER
WHEN ORDERING ANY PAINTED PANEL TO INDICATE
COLOR OF UNIT:

1-ORANGE	5-BLACK
2-WHITE	6-CATERPILLAR YELLOW
3-SPECTRUM GRAY	7-CATO GOLD
4-SUNBELT GREEN	8-RED

THE SERIAL NUMBER MAY BE REQUIRED.

DCA-500SSK — ENCLOSURE #1 ASSY.

ENCLOSURE #1 ASSY.

<u>NO</u>	<u>PART NO</u>	<u>PART NAME</u>	<u>QTY.</u>	<u>REMARKS</u>
1	8485111002	BASE	1	
2	3875116304	FOOR PANEL	1	
3	7435116104	FLOOR PANEL	1	
4	0017108020	HEX. HEAD BOLT	18	
5	8485118004	GUIDE PANEL, AIR	1	
6	0017108020	HEX. HEAD BOLT	4	
7	C4424002303	FRONT FRAME	1	
	C4494100103	LINING	1	
8	C4424000503	FRONT FRAME	1	
	C4494100103	LINING	1	
9	C4424000702	FRONT FRAME	1	
	C4494100103	LINING	1	
10	C4424000602	FRONT FRAME	1	
	C4494100103	LINING	1	
11	0017108020	HEX. HEAD BOLT	28	
12	C4424700004	GUIDE PANEL, AIR	1	
	C4494100103	LINING	1	
13	C4424300303	GUIDE PANEL, AIR	1	
	C4494100103	LINING	1	
14	C4424300003	GUIDE PANEL, AIR	1	
	C4494100103	LINING	1	
15	0017108020	HEX. HEAD BOLT	30	
16	0019210025	HEX. HEAD BOLT	8	
17	8485125203	COVER, FRONT FRAME	1	
18	8485125104	COVER, FRONT FRAME	1	
	8465924104	LINING	1	
19	0019208020	HEX. HEAD BOLT	32	
20	0845042703	FILLER BRACKET	1	
21	0019208020	HEX. HEAD BOLT	4	
22	7525125304	COVER	1	
23	0019206016	HEX. HEAD BOLT	6	
24	C442420003	COVER, FRONT FRAME	1	
25	0019208020	HEX. HEAD BOLT	12	
26	0600500090	EMBLEM	1	
27	0021106020	MACHINE SCREW	2	
28	C4434000112	CENTER FRAME	1	

ENCLOSURE #1 ASSY.

ENCLOSURE #1 ASSY.

<u>NO</u>	<u>PART NO</u>	<u>PART NAME</u>	<u>QTY.</u>	<u>REMARKS</u>
29	0010120075	HEX. HEAD BOLT	6	
	0030020000	HEX.NUT	6	
	0040020000	LOCK WASHER	6	
	0041220000	PLAIN WASHER	12	
30	0010120065	HEX. HEAD BOLT	8	
	0030020000	HEX. NUT	8	
	0040020000	LOCK WASHER	8	
	0041220000	PLAIN WASHER	16	
31	C4434200013	COVER	2	
32	0017108020	HEX. HEAD BOLT	12	
	0207008000	HEX. NUT	12	
33	8485161103	ROOF PANEL	1	
34	C4464100203	ROOF PANEL	1	
35	C4464100303	ROOF PANEL	1	
36	0207008000	HEX. NUT	14	
37	0800251701	FILLER COVER	1	
38	0019206016	HEX. HEAD BOLT	2	
39	0019208020	HEX. HEAD BOLT	30	

DCA-500SSK — ENCLOSURE #2 ASSY.

ENCLOSURE #2 ASSY.

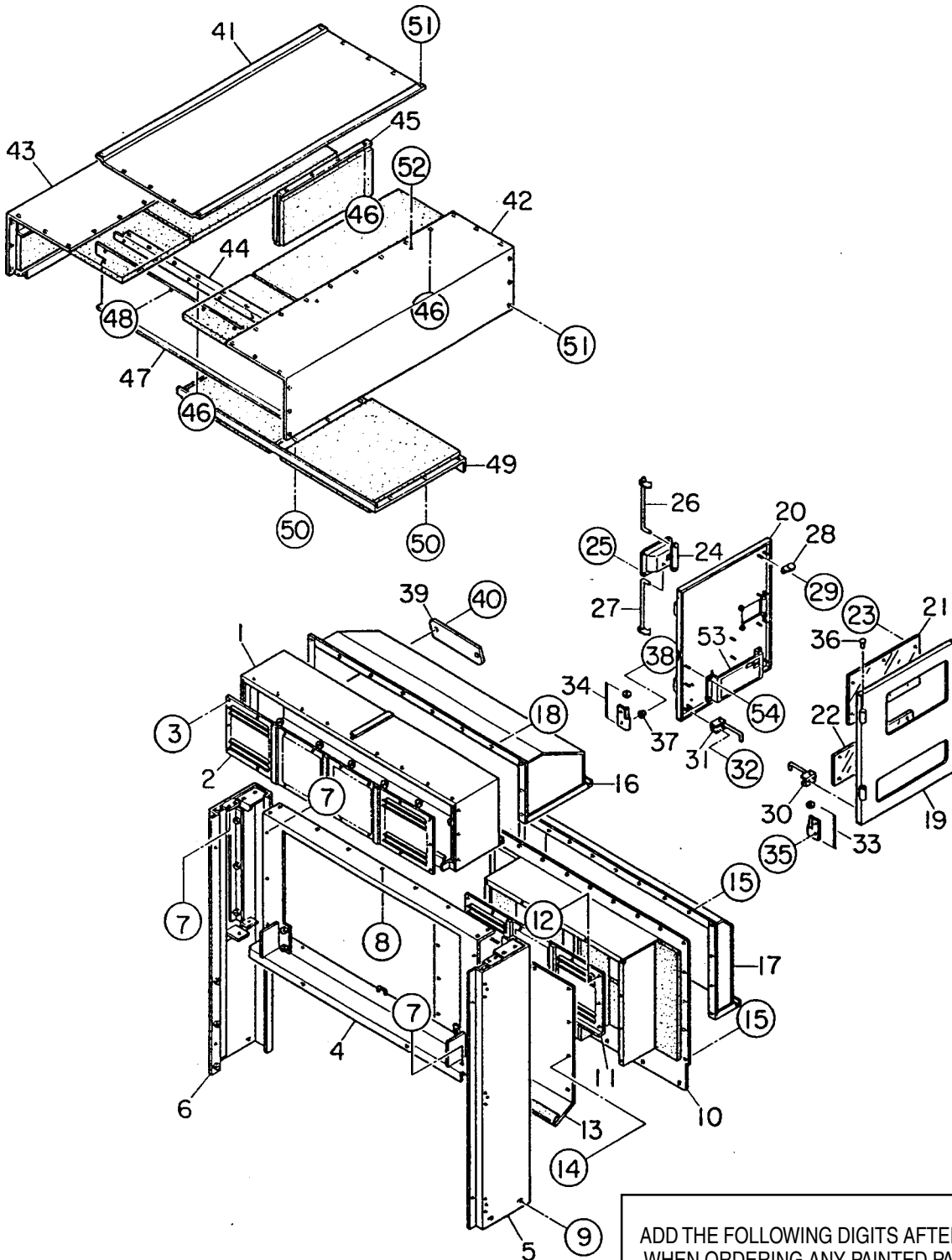

ADD THE FOLLOWING DIGITS AFTER THE PART NUMBER
WHEN ORDERING ANY PAINTED PANEL TO INDICATE
COLOR OF UNIT:

- | | |
|-----------------|----------------------|
| 1-ORANGE | 5-BLACK |
| 2-WHITE | 6-CATERPILLAR YELLOW |
| 3-SPECTRUM GRAY | 7-CATO GOLD |
| 4-SUNBELT GREEN | 8-RED |

THE SERIAL NUMBER MAY BE REQUIRED.

DCA-500SSK — ENCLOSURE #2 ASSY.

ENCLOSURE #2 ASSY.

<u>NO</u>	<u>PART NO</u>	<u>PART NAME</u>	<u>QTY.</u>	<u>REMARKS</u>
1	C4444000003	REAR FRAME	1	
2	3875151004	LOUVER PANEL	1	
3	0205006000	HEX. NUT	21	
	0042306000	LOCKWASHER	21	
	0042406000	PLAIN WASHER	21	
4	C4444000103	REAR FRAME	1	
5	C4444000203	REAR FRAME	1	
6	C4444000303	REAR FRAME	1	
7	0017110025	HEX. HEAD BOLT	18	
8	0017108020	HEX. HEAD BOLT	5	
9	0019210025	HEX. HEAD BOLT	4	
10	7975155003	COVER, REAR FRAME	1	
	3875944104	LINING	1	
11	3875151104	LOUVER PANEL	1	
12	0205006000	HEX.NUT	16	
	0042306000	LOCKWASHER	16	
	0042406000	PLAIN WASHER	16	
13	7975156004	DUCT COVER	1	
	8495946104	LINING	1	
14	0017108020	HEX. HEAD BOLT	17	
15	0019208020	HEX. HEAD BOLT	23	
16	C4444300703	VISOR	1	
17	3875165803	VISOR	1	
18	0019208020	HEX. HEAD BOLT	12	
19	7975143003	DOOR, REAR FRAME	1	
20	7975143113	DOOR, REAR FRAME	1	
21	3875147204	WINDOW PLATE	1	
22	3875147304	WINDOW PLATE	1	
23	0207306000	HEX. NUT	12	
24	B9114000102	DOOR HANDLE	1	139LKDNUSA
25	0021806016	MACHINE SCREW	4	
26	7975146004	DOOR ROD	1	
27	7975146104	DOOR ROD	1	
28	0845050704	STAY	4	
29	0207006000	HEX. NUT	8	

DCA-500SSK — ENCLOSURE #2 ASSY.

ENCLOSURE #2 ASSY.

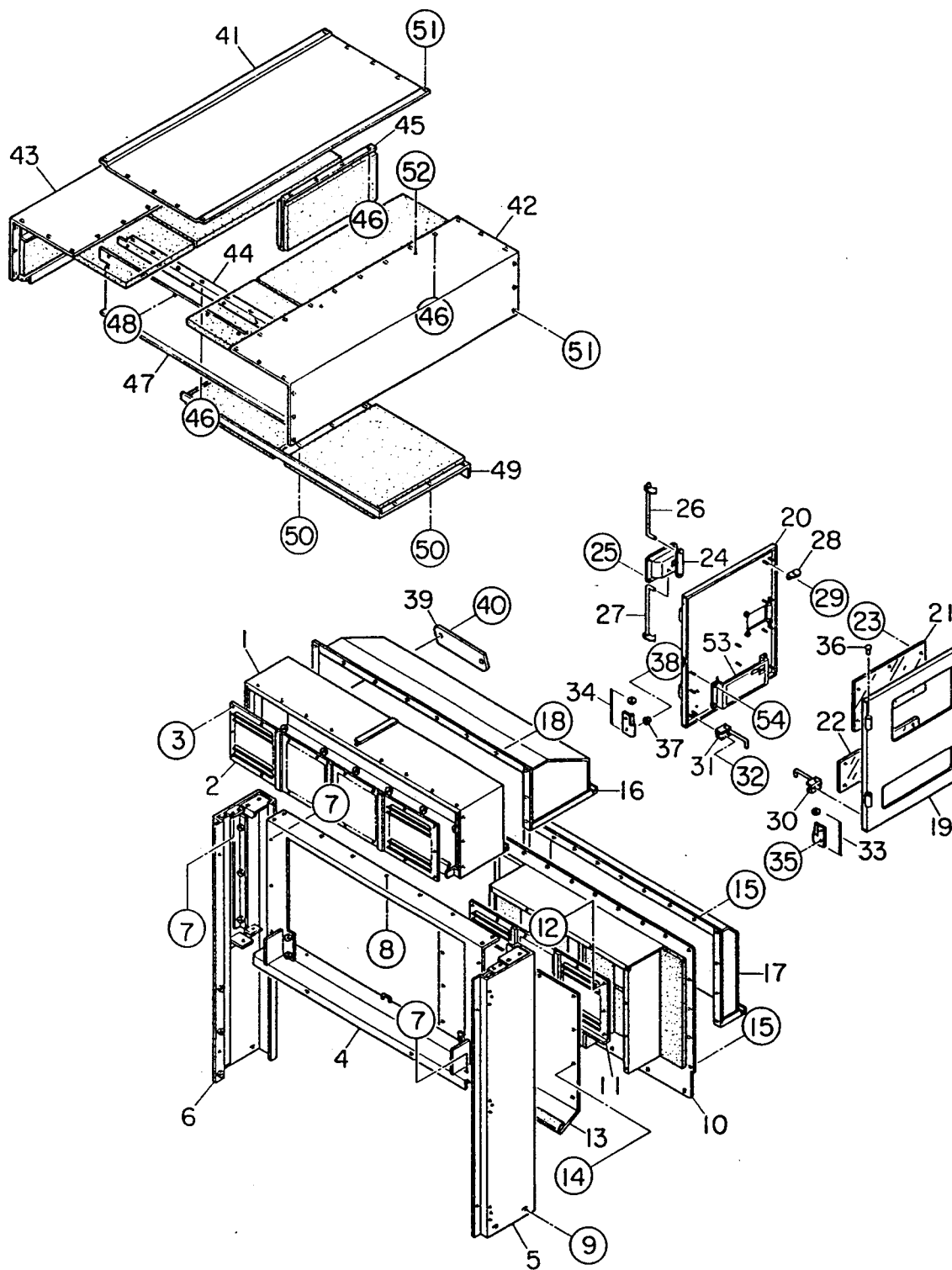

ENCLOSURE #2 ASSY.

<u>NO</u>	<u>PART NO</u>	<u>PART NAME</u>	<u>QTY.</u>	<u>REMARKS</u>
30	0805011304	STOPPER, DOOR	1	
31	0805011204	STOPPER, DOOR	1	
32	0207006000	HEX. NUT	4	
33	0845047104	HINGE	2	
	0845045004	WASHER	2	
34	0845047204	HINGE	2	
	0845045004	WASHER	2	
35	0019208020	HEX. HEAD BOLT	6	
36	0845031504	CAP	4	
37	0601850097	STOPPER	2	
38	0021008025	MACHINE SCREW	2	
39	0600500090	EMBLEM	1	
40	0021106020	MACHINE SCREW	2	
41	C4464200303	ROOF PANEL	1	
	8485960104	LINING	1	
42	C4464200403	ROOF PANEL	1	
	8485960104	LINING	1	
43	C4464200503	ROOF PANEL	1	
	8485960104	LINING	1	
44	C4464500304	GUIDE	1	
45	C4464500204	PANEL	1	
	8485960104	LINING	1	
46	0207008000	HEX. NUT	27	
47	C4464500404	PANEL	1	
48	00171008020	HEX. HEAD BOLT	11	
49	8485166004	COVER, ROOF PANEL	1	
	8485968104	LINING	1	
50	0017108020	HEX. HEAD BOLT	9	
51	0019208020	HEX. HEAD BOLT	30	
52	0019210025	HEX. HEAD BOLT	4	
53	B9114500104	DOOR POCKET	1	
54	0207006000	HEX.NUT	4	

ADD THE FOLLOWING DIGITS AFTER THE PART NUMBER
WHEN ORDERING ANY PAINTED PANEL TO INDICATE
COLOR OF UNIT:

1-ORANGE	5-BLACK
2-WHITE	6-CATERPILLAR YELLOW
3-SPECTRUM GRAY	7-CATO GOLD
4-SUNBELT GREEN	8-RED

THE SERIAL NUMBER MAY BE REQUIRED.

DCA-500SSK — ENCLOSURE #3 ASSY.

ENCLOSURE #3 ASSY.

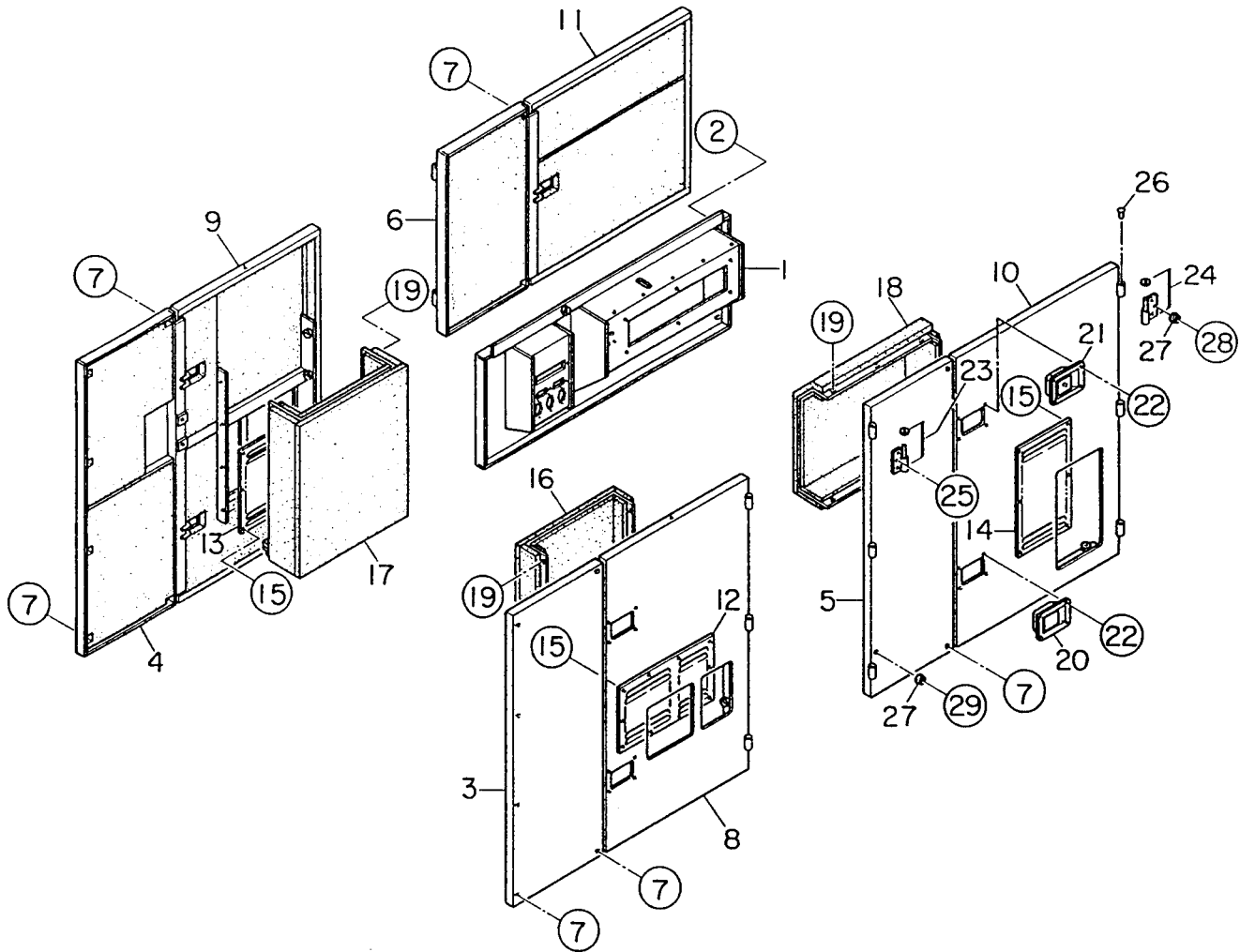

ADD THE FOLLOWING DIGITS AFTER THE PART NUMBER
WHEN ORDERING ANY PAINTED PANEL TO INDICATE
COLOR OF UNIT:

1-ORANGE	5-BLACK
2-WHITE	6-CATERPILLARYELLOW
3-SPECTRUM GRAY	7-CATO GOLD
4-SUNBELT GREEN	8-RED

THE SERIAL NUMBER MAY BE REQUIRED.

DCA-500SSK — ENCLOSURE #3 ASSY.

ENCLOSURE #3 ASSY.

<u>NO</u>	<u>PART NO</u>	<u>PART NAME</u>	<u>QTY.</u>	<u>REMARKS</u>
1	C4454201603	SPASHER PANEL	1	
2	0019110070	HEX. HEAD BOLT	6	
	0042310000	LOCK WASHER	6	
	0042410000	PLAIN WASHER	6	
3	8485172003	SIDE PANEL	1	
	8485972104	LINING	1	
4	8485172103	SIDE PANEL	1	
	8485972304	LINING	1	
5	8485172203	SIDE PANEL	1	
	8485972503	LINING	1	
6	8485172303	SIDE PANEL	1	
	8485972704	LINING	1	
7	7525151004	LOUVER PANEL	1	
8	7525151104	LOUVER PANEL	1	
9	0205006000	HEX. NUT	16	
	0042306000	LOCK WASHER	16	
	0042406000	PLAIN WASHER	16	
10	8215176004	DUCT	1	
	8485976704	LINING	1	
11	8485176104	DUCT	1	
	8485976304	LINING	1	
12	0017108020	HEX. HEAD BOLT	12	
13	0019108070	HEX.HEAD BOLT	16	
	0042308000	LOCK WASHER	16	
	0042408000	PLAIN WASHER	16	
14	8485171003	SIDE DOOR	1	
	8485970103	LINING	1	
15	8485171103	SIDE DOOR	1	
	8485970303	LINING	1	
16	7975171403	SIDE DOOR	1	
	8485970503	LINING	1	
17	7975171203	SIDE DOOR	1	
	7975970704	LINING	1	

ENCLOSURE #3 ASSY.

DCA-500SSK — ENCLOSURE #3 ASSY.

ENCLOSURE #3 ASSY.

<u>NO</u>	<u>PART NO</u>	<u>PART NAME</u>	<u>QTY.</u>	<u>REMARKS</u>
18	7525151504	LOUVER PANEL	1	
19	7525151404	LOUVER PANEL	1	
20	7975151004	LOUVER PANEL	1	
21	0205006000	HEX. NUT	28	
	0042306000	LOCK WASHER	28	
	0042406000	PLAIN WASHER	28	
22	8485176004	DUCT	1	
	7865976104	LINING	1	
25	0017108020	HEX. HEAD BOLT	22	
26	0825007362	DOOR HANDLE	3	
27	0021806016	MACHINE SCREW	28	
28	0845046904	HINGE	8	
	0845045004	WASHER	8	
29	0845047004	HINGE	8	
	0845045004	WASHER	8	
30	0019208020	HEX. HEAD BOLT	39	
31	0845031504	CAP	16	
32	0601850097	STOPPER	10	
33	0021008025	MACHINE SCREW	9	
34	0021008020	MACHINE SCREW	1	
35	B9114000002	DOOR HANDLE	4	039LKDNUSA

DCA-500SSK — RUBBER SEAL ASSY.

RUBBER SEAL ASSY.

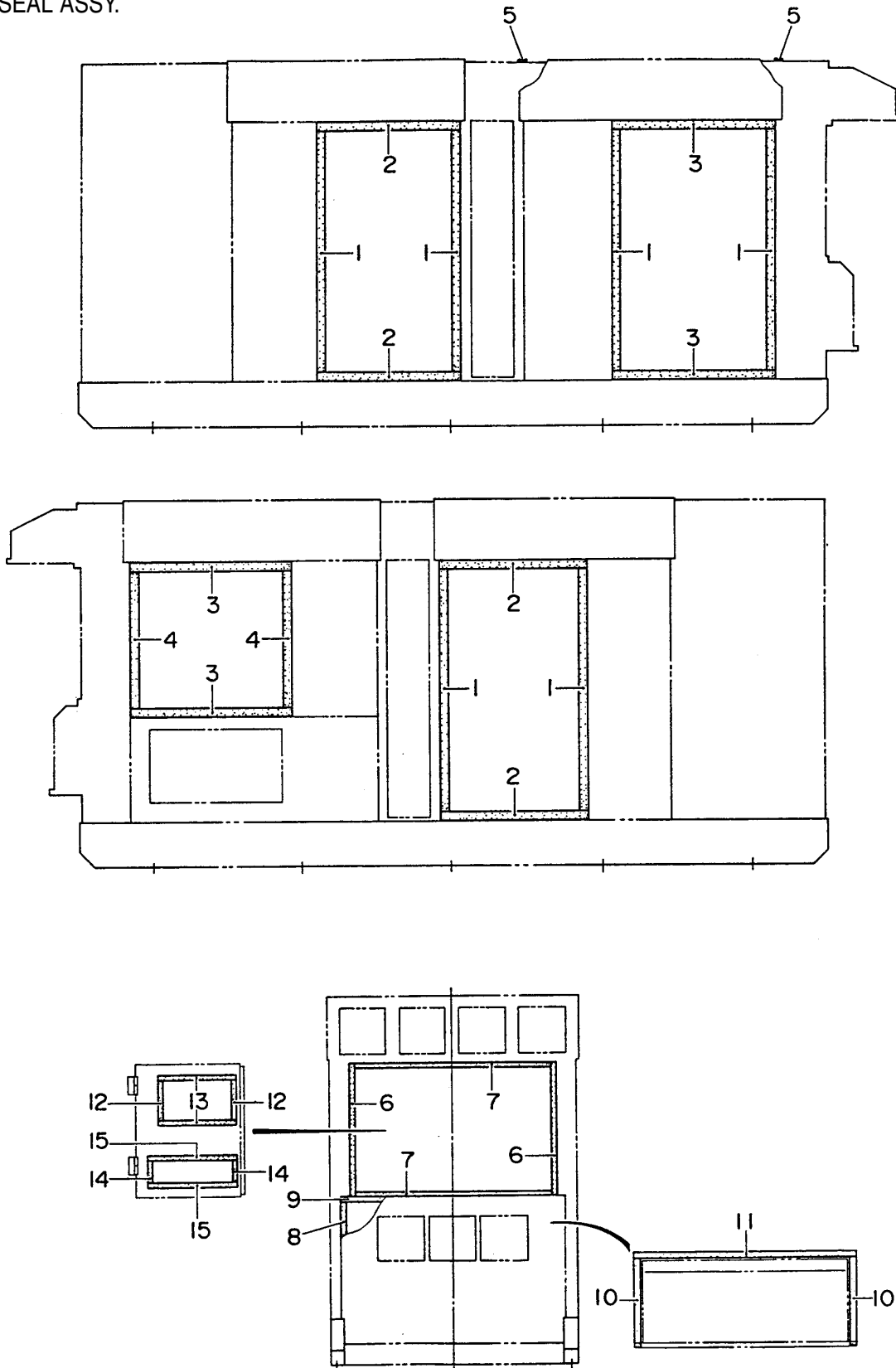

DCA-500SSK — RUBBER SEAL ASSY.

RUBBER SEAL ASSY.

<u>NO</u>	<u>PART NO</u>	<u>PART NAME</u>	<u>QTY.</u>	<u>REMARKS</u>
1	0228901640	RUBBER SEAL	6	
2	0228900970	RUBBER SEAL	4	
3	0228901100	RUBBER SEAL	4	
4	0228900990	RUBBER SEAL	2	
5	0229201650	RUBBER SEAL	2	
6	0228800860	RUBBER SEAL	2	
7	0228801380	RUBBER SEAL	2	
8	0229200780	RUBBER SEAL	2	
9	0229201490	RUBBER SEAL	1	
10	0229200595	RUBBER SEAL	2	
11	0229201490	RUBBER SEAL	1	
12	0228100280	RUBBER SEAL	2	
13	0228100520	RUBBER SEAL	2	
14	0228100150	RUBBER SEAL	2	
15	0228100580	RUBBER SEAL	2	

DCA-500SSK — NAMEPLATE AND DECALS

NAME PLATE AND DECALS

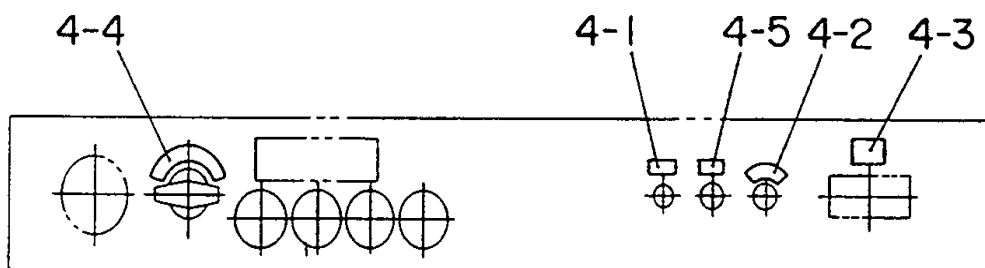
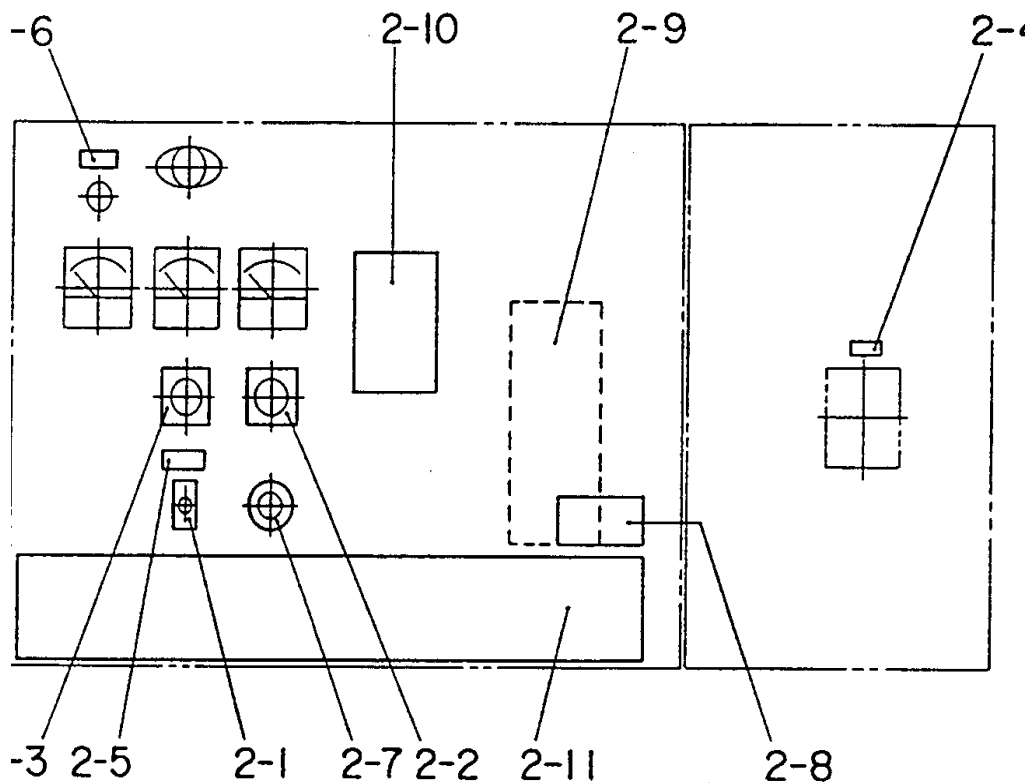

DCA-500SSK — NAMEPLATE AND DECALS

NAME PLATE AND DECALS

<u>NO</u>	<u>PART NO</u>	<u>PART NAME</u>	<u>QTY.</u>	<u>REMARKS</u>
CONTROL BOX GROUP				
2-1	0800520100	PLATE; ON-OFF	1	AT-202
2-2	0800520904	PLATE; AMMETER CHANGE-OVER SWITCH	1	N-2438
2-3	0800520814	PLATE; VOLTMETER CHANGE-OVER SWITCH	1	N-2439
2-4	0840624504	DECAL; CIRCUIT BREAKER	1	S-3031
2-5	0840624604	DECAL; PANEL LIGHT	1	S-3032
2-6	0840624704	DECAL; PILOT LAMP	1	S-3033
2-7	0840624804	DECAL; VOLTAGE REGULATOR	1	S-3034
2-8	B9531100604	DECAL; WARNING ELECTRIC SHOCK HAZARD	1	B93110060
2-9	C9521203003	DECAL; SETTING FOR OUTPUT VOLTAGE	1	C92120300
2-10	C4561101803	DECAL; WHISPERWATT 600	1	C46110180
ENGINE OPERATING PANEL GROUP				
4-1	0800588004	DECAL: THROTTLE LEVER	1	N-3808
4-2	0800682004	DECAL: BATTERY SWITCH	1	S-874
4-3	0800686004	DECAL: STOP BUTTON	1	S-878
4-4	0840625004	DECAL: PREHEAT LAMP	1	S-3036
4-5	0840631204	DECAL: RED CIRCLE	1	S-3346
4-6	9039208694	DECAL: HIGH-LOW	1	S-4451
4-7	9039208704	DECAL: ENGINE SPEED	1	S-4452
4-8	0840655004	DECAL: HEATER SWITCH	1	S-4506
4-9	0840655804	DECAL: STARTER SWITCH	1	S-4515

DCA-500SSK — NAMEPLATE AND DECALS

NAME PLATE AND DECALS

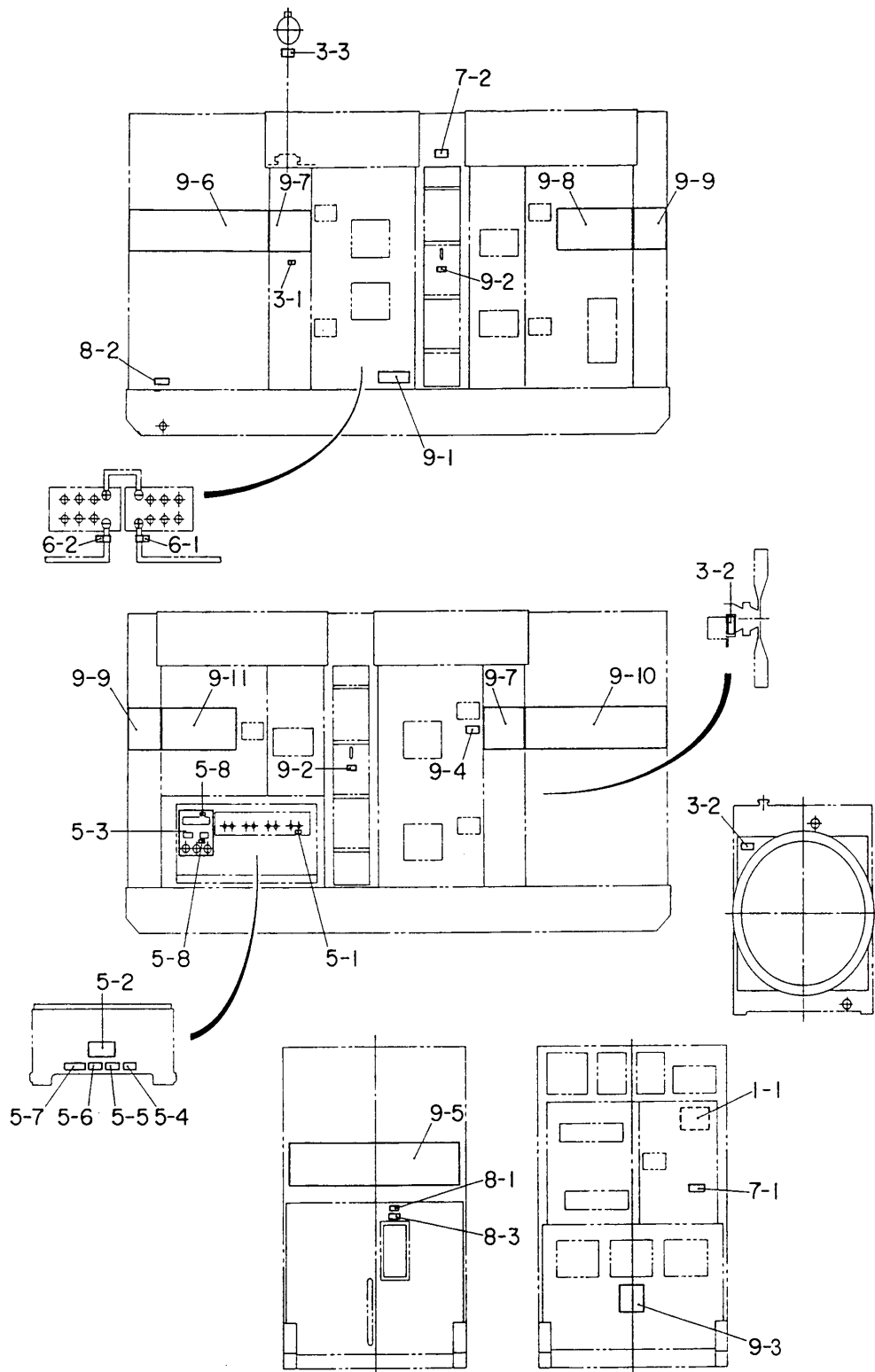

DCA-500SSK — NAMEPLATE AND DECALS

NAME PLATE AND DECALS

<u>NO</u>	<u>PART NO</u>	<u>PART NAME</u>	<u>QTY.</u>	<u>REMARKS</u>
1-1	C4551001002	DECAL: HANDLING PROCEDURES	1	C45100100
1-2	8490611303	DECAL: PROCEDURES FOR START UP	1	S-4519
ENGINE & RADIATOR GROUP				
3-1	0800616204	DECAL: WATER DRAIN COCK	1	S-705
3-2	0800689204	DECAL: COOLING WATER	1	S-961
3-3	6360610304	DECAL: WATER	1	S-1880
3-4	0840611903	DECAL: PRECAUTIONS ON HANDLING	1	S-2570
3-5	B9504000404	DECAL: WARNING MOVING PARTS	2	B90400040
3-6	B9504100104	DECAL: WARNING HOT COOLANT	1	B90410010
3-7	0966810000	DECAL: WARNING	1	REPLACES 0600501100
3-8	6162937111	DECAL: FUEL PRIMING	1	REPLACES 0600500011
OUTPUT TERMINAL GROUP				
5-1	C0551000404	DECAL; 3-PHASE OUTPUT TERMINAL	1	C05100040
5-2	0840614104	DECAL; GROUND	1	S-2635
5-3	9039202064	DECAL; START CONTACT	1	S-4468
5-4	0840655704	DECAL; TERMINAL COVER STOPPER	1	S-4516
5-5	B4551000103	DECAL; RECEPTACLE & CIRCUIT BREAKER	1	B45100010
5-6	B9511100304	DECAL; WARNING	1	B91110030
5-7	B9511100404	DECAL; WARNING ELECTRIC SHOCK HAZARD	1	B91110040
5-8	B9531100504	DECAL; WARNING ELECTRIC SHOCK HAZARD	1	B93110050
5-9	C1551000404	DECAL; 240/139 VOLT	2	C15100040
BATTERY GROUP				
6-1	0800689404	DECAL: +	2	S-2090
6-2	0800689504	DECAL: -	1	S-2091
MUFFLER ASSY.				
7-1	B9504200004	DECAL; WARNING ENGINE EXHAUST	1	B90420000
7-2	B9511100204	DECAL: CAUTION HOT SURFACES	1	B91110020
FUEL TANK GROUP				
8-1	0800688404	DECAL; FUEL INLET	1	S-1344
8-2	0800688504	DECAL; FUEL OUTLET	1	S-1345
8-3	1320620904	DECAL; DIESEL FUEL	1	S-1756
8-4	6360620004	DECAL; FUEL DRAIN PLUG	1	S-1883
8-5	0840607104	DECAL; FUEL GAUGE	1	S-2365
8-6	B9504500004	DECAL; WARNING DIESEL FUEL	1	B90450000
ENCLOSURE GROUP				
9-1	0800615102	DECAL; CAUTION AGAINST OIL AND	1	S-544A
9-2	1320610603	DECAL; WATER-OIL	1	S-1760
9-3	1320621504	DECAL; SUPPORT HOOK	2	S-2257
9-4	0840625902	DECAL; MQ	1	S-3057
9-5	B9504000304	DECAL; CAUTION HOT PARTS	1	B90400030
9-6	B9521100404	DECAL; SAFETY INSTRUCTIONS	1	B92110040
9-7	B9531100604	DECAL; WARNING ELECTRIC SHOCK HAZARD	1	B93110060
9-8	C4561101603	STRIPE	1	
9-9	C4561101503	STRIPE	1	
9-10	C4561101303	STRIPE	1	
9-11	C4561101204	STRIPE	2	
9-12	C4561101704	STRIPE	2	
9-13	C4561101104	STRIPE	2	
9-14	C4561101403	STRIPE	1	
9-15	C4561101003	STRIPE	1	
9-16	C4561100904	STRIPE	2	

PAYMENT TERMS

Terms of payment for parts are net 10 days.

FREIGHT POLICY

All parts orders will be shipped collect or prepaid with the charges added to the invoice. All shipments are F.O.B. point of origin. Multiquip's responsibility ceases when a signed manifest has been obtained from the carrier, and any claim for shortage or damage must be settled between the consignee and the carrier.

MINIMUM ORDER

The minimum charge for orders from Multiquip is \$15.00 net. Customers will be asked for instructions regarding handling of orders not meeting this requirement.

RETURNED GOODS POLICY

Return shipments will be accepted and credit will be allowed, subject to the following provisions:

1. A Returned Material Authorization must be approved by Multiquip prior to shipment.
2. To obtain a Return Material Authorization, a list must be provided to Multiquip Parts Sales that defines item numbers, quantities, and descriptions of the items to be returned.
 - a. The parts numbers and descriptions must match the current parts price list.
 - b. The list must be typed or computer generated.
 - c. The list must state the reason(s) for the return.
 - d. The list must reference the sales order(s) or invoice(s) under which the items were originally purchased.
 - e. The list must include the name and phone number of the person requesting the RMA.
3. A copy of the Return Material Authorization must accompany the return shipment.

4. Freight is at the sender's expense. All parts must be returned freight prepaid to Multiquip's designated receiving point.
5. Parts must be in new and resalable condition, in the original Multiquip package (if any), and with Multiquip part numbers clearly marked.
6. The following items are not returnable:
 - a. Obsolete parts. (If an item is listed in the parts price book as being replaced by another item, it is obsolete.)
 - b. Any parts with a limited shelf life (such as gaskets, seals, "O" rings, and other rubber parts) that were purchased more than six months prior to the return date.
 - c. Any line item with an extended dealer net price of less than \$5.00.
 - d. Special order items.
 - e. Electrical components.
 - f. Paint, chemicals, and lubricants.
 - g. Decals and paper products.
 - h. Items purchased in kits.
7. The sender will be notified of any material received that is not acceptable.
8. Such material will be held for 5 working days from notification, pending instructions. If a reply is not received within 5 days, the material will be returned to the sender at his expense.
9. Credit on returned parts will be issued at dealer net price at time of the original purchase, less a 15% restocking charge.
10. In cases where an item is accepted for which the original purchase document can not be determined, the price will be based on the list price that was effective twelve months prior to the RMA date.
11. Credit issued will be applied to future purchases only.

PRICING AND REBATES

Prices are subject to change without prior notice. Price changes are effective on a specific date and all orders received on or after that date will be billed at the revised price. Rebates for price declines and added charges for price increases will not be made for stock on hand at the time of any price change.

Multiquip reserves the right to quote and sell direct to Government agencies, and to Original Equipment Manufacturer accounts who use our products as integral parts of their own products.

SPECIAL EXPEDITING SERVICE

A \$20.00 to \$50.00 surcharge will be added to the invoice for special handling including bus shipments, insured parcel post or in cases where Multiquip must personally deliver the parts to the carrier.

LIMITATIONS OF SELLER'S LIABILITY

Multiquip shall not be liable here under for damages in excess of the purchase price of the item with respect to which damages are claimed, and in no event shall Multiquip be liable for loss of profit or good will or for any other special, consequential or incidental damages.

LIMITATION OF WARRANTIES

No warranties, express or implied, are made in connection with the sale of parts or trade accessories nor as to any engine not manufactured by Multiquip. Such warranties made in connection with the sale of new, complete units are made exclusively by a statement of warranty packaged with such units, and Multiquip neither assumes nor authorizes any person to assume for it any other obligation or liability whatever in connection with the sale of its products. A part from such written statement of warranty, there are no warranties, express, implied or statutory, which extend beyond the description of the products on the face hereof.

PARTS AND OPERATION MANUAL

HERE'S HOW TO GET HELP

*PLEASE HAVE THE MODEL AND SERIAL NUMBER
ON-HAND WHEN CALLING*

PARTS DEPARTMENT

800/427-1244 or 310/537-3700

FAX: 800/672-7877 or 310/637-3284

SERVICE DEPARTMENT

800/835-2551 or 310/537-3700

FAX: 310/638-8046

WARRANTY DEPARTMENT

800/835-2551 or 310/537-3700

FAX: 310/638-8046

MAIN

800/421-1244 or 310/537-3700

FAX: 310 - 537-3927

Manufactured for Multiquip Inc.
by
DENYO MANUFACTURING, CO., USA



MULTIQUIP INC.

POST OFFICE BOX 6254

CARSON, CA 90749

310-537-3700 • 800-421-1244

FAX: 310-537-3927

E-MAIL: mq@multiquip.com

WWW: multiquip.com

Atlanta • Boise • Dallas • Houston • Newark
Quebec, Canada • Manchester, UK • Rio De Janeiro, BR • Guadalajara, MX